

1980

DIXIE-NARCO

SERVICE MANUAL AND PARTS LIST

001-2327AE thru 850-2374BE
0001-2373CE

Bottle / Double Depth Can Venders



PEPSI ONLY

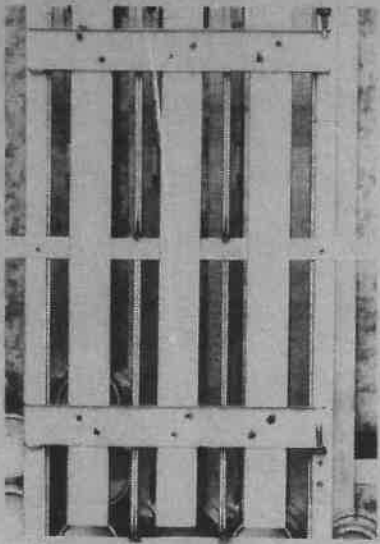

- DCB 156/93-6
- DCB 228/132-6
- DCB 264/156-6
- DCB 318/183-6
- DCB 304/176-8
- DCB 352/208-8
- DCB 424/244-8



The number 001 - 2327AE on the front cover of the manual is the beginning Serial Number for the Models listed on the front cover.

The number 850 - 2374BE is the ending Serial Number before introducing another Serial Number series which is: Beginning Serial Number 0001 2373CE.

Thus, a Serial Number series ends with Number 850 - 2374BE. The new Serial Number series begins with Number 0001 - 2373CE.

The letter C indicates the quarter of the calendar year in which the Vender was manufactured.

The letter E indicates the calendar year in which the Vender was manufactured.

Thus C = 3rd quarter

E = Year 1980

The date system started in 1976

Thus,

For a given year the first letter is the quarter, ie,

A = First Quarter

B = Second Quarter

C = Third Quarter

D = Fourth Quarter

The second letter is the Year, ie,

A = Year, 1976

B = Year, 1977

C = Year, 1978

D = Year, 1979

E = Year, 1980

F = Year, 1981

G = Year, 1982

H = Year, 1983

I = Year, 1984

J = Year, 1985

- WARRANTY -

Dixie-Narco Warrants to the original purchaser of a Dixie-Narco unit all parts thereof (except light bulbs, fuses, or finish) to be free from defects in material and workmanship, under normal use and service for a period of 15 months from the date of shipment of the unit from either our plant or warehouse.

The term "original purchaser" as used in this warranty shall be deemed to mean that person, firm, association, or corporation to which the machine was sold originally.

Dixie-Narco's obligation under this warranty is limited to repairing or replacing without charge any part which upon our examination and to our satisfaction was defective in material or in workmanship and which failed under normal operating conditions and service.

The hermetically sealed refrigeration system, consisting of the motor compressor, condenser, evaporator and the refrigerant tubing is warranted for a total period of five (5) years and three (3) months from date of shipment.

The vend motor is warranted for a total period of five (5) years and three (3) months from date of shipment.

The five year warranty does not apply to any electrical controls, fan motors, overload switches, starting relays, temperature controls, wiring harnesses, cabinet or finish. Dixie-Narco's obligation under this warranty on the sealed refrigeration system referred to above is limited to repairing and returning or replacing at Dixie-Narco's option any unit with a similar unit when upon examination and to our satisfaction it was determined to have been defective. If our examination reveals that the unit is inoperative because of a defective accessory, both cost of repairs and freight charges will be paid by the customer.

Dixie-Narco will pay transportation charges under this warranty on all parts replaced or repaired when transportation has been made in the most economical way. If special handling or special transportation is used or requested, the charges will be paid by the customer.

This warranty only applies to units located within the United States and when operated in normal conditions and with electrical power supplies of 110/120 volts, 60 cycle. Further, the warranty is voided when a unit or any part has been subject to misuse, neglect, alteration, without proper authorization, accident, or damage caused by transportation, flood, civil disorder, fire or the Acts of God.

"Return Material Tags," indicating model number of unit, serial number, and explanation of defect, must accompany all returned parts or units. "Return Material Tags" will be furnished upon request.

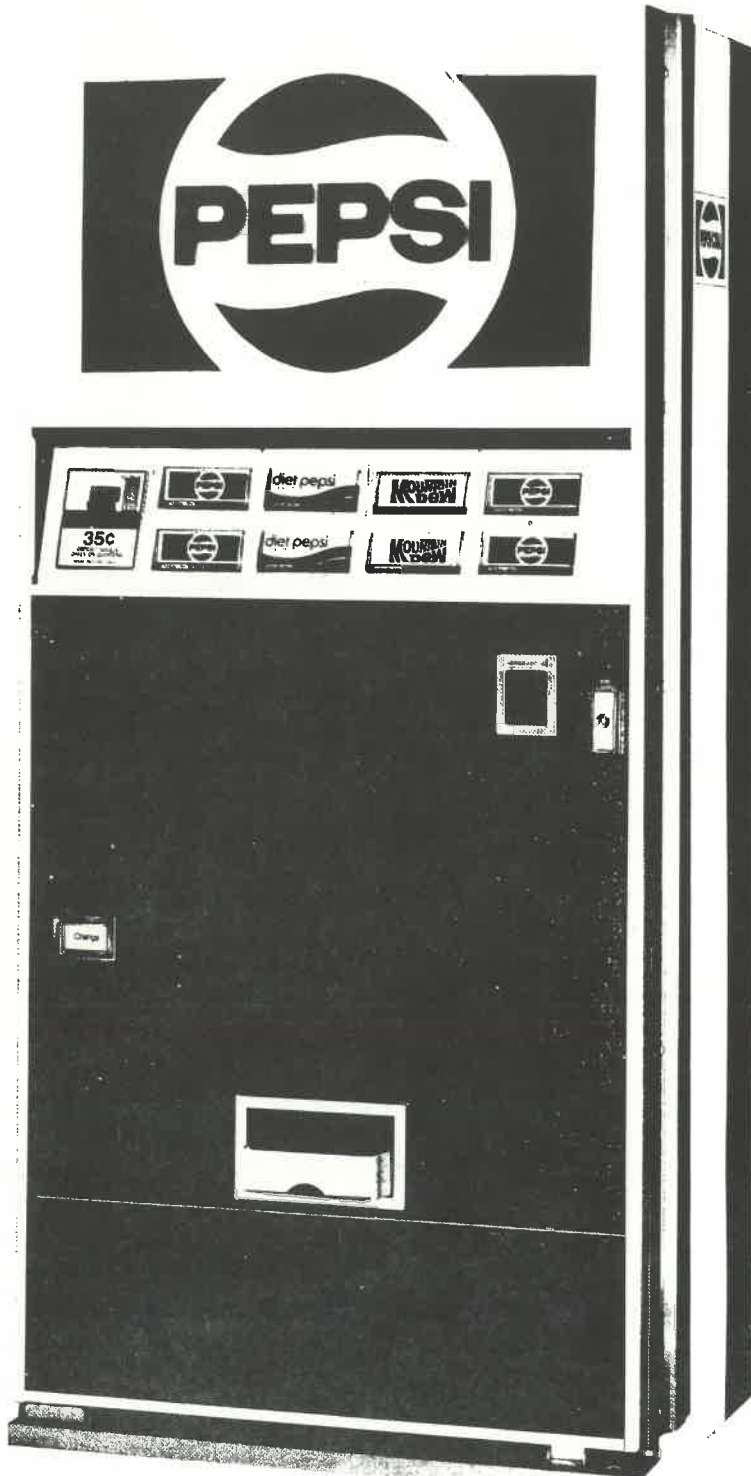

DCB 156/93-6
Height: 56-3/4"
Width: 28-3/8"
Depth: 26"
Shipping Wt.: 475 lbs.
Capacity: Can, 12 oz. - 156
Bottle, regular - 93

DCB 228/132-6
Height: 66-3/8"
Width: 28-3/8"
Depth: 26"
Shipping Wt.: 535 lbs.
Capacity: Can, 12 oz. - 228
Bottle, regular - 132

DCB 264/156-6
Height: 72"
Width: 28 3/8"
Depth: 26"
Shipping Wt.: 585 lbs.
Capacity: Can, 12 oz. - 264
Bottle, regular - 156

DCB 318/183-6
Height: 79-1/2"
Width: 28-3/8"
Depth: 26"
Shipping Wt.: 625 lbs.
Capacity: Can, 12 oz. - 3/8
Bottle, regular - 183

DCB 304/176-8
Height: 66-3/4"
Width: 37-1/8"
Depth: 26"
Shipping Wt.: 665 lbs.
Capacity: Can, 12 oz. - 304
Bottle, regular - 176

DCB 352/208-8
Height: 72
Width: 37-1/8"
Depth: 26"
Shipping Wt.: 710
Capacity: Can, 12 oz. - 352
Bottle, regular - 208

DCB 424/244-8
Height: 79-1/2"
Width: 37-1/8"
Depth: 26"
Shipping Wt.: 760
Capacity: Can, 12 oz. - 424
Bottle, regular - 244

CONTENTS

WHAT TO DO WHEN YOU GET A NEW VENDER	
SET IT UP	4
LOAD THE VENDER	5
CHECK IT OUT	6
PUT IT TO WORK	7
HOW THE VENDING MECHANISM WORKS	
ELECTRICAL PARTS	8
STUDY — vending cycle and across the line wiring diagram	14
VEND CYCLE.	15
HOW TO TAKE CARE OF THE VENDER	
WHAT TO CLEAN	17
WHEN AND WHAT TO LUBRICATE	17
THINGS TO ADJUST	18
HOW TO CORRECT COMMON VENDING TROUBLES.	25
HOW THE REFRIGERATION SYSTEM WORKS	
MECHANICAL PARTS	28
ELECTRICAL PARTS	29
ELECTRICAL OPERATION	32
ELECTRICAL CIRCUITS AND CIRCUIT DIAGRAMS	34
REFRIGERATION CYCLE	39
HOW TO TAKE CARE OF THE REFRIGERATION SYSTEM	
WHAT TO CLEAN	40
WHEN AND WHAT TO LUBRICATE	40
CORRECTING TROUBLES	40
HOW TO CORRECT COMMON REFRIGERATION TROUBLES.	41
ACROSS THE LINE DIAGRAM	52
WIRING DIAGRAM.	54
PARTS LIST	56

WHAT TO DO WHEN YOU GET A NEW VENDER

– SET IT UP –

KEYS

Keys are tied inside the can/bottle delivery port.

SERIAL NUMBER PLATE

The serial number plate is attached to the left side of the cabinet and to the inner door.

COIN MECHANISM

The coin mechanism is shipped in a separate package.

To install, do this:

1. Open the inner door.
2. Remove the slug rejector.
3. Line the three holes in the coin mechanism with the three screws and push the coin mechanism over the three screws. Let the coin mechanism drop down onto the screws, tighten the screws.
4. Reinstall the slug rejector.
5. Connect the changer plug to the socket.

APPLICATION OF CUSTOMER INSTRUCTION PLATE

1. Clean and dry the surface of the inset in the selector panel.
2. Remove the “backing” from the plate (pressure sensitive).
3. Apply to the surface of the inset and press or roll firmly in place.

– LOAD THE VENDER –

ADJUSTMENTS

1. The Adaptables are shipped set to dispense cans.
2. For adjustments, look under “Things to Adjust”.

LOAD THE VENDER

1. Read thoroughly, “Things To Adjust”.
2. Adjust for dispensing cans or bottles.
3. Load the vender with eight (8) cans or bottles.
4. Install coin changer.
5. Plug vender “in” - Dispense cans or bottles to check vending operation.

WHAT TO DO WHEN YOU GET A NEW VENDER (Cont.)

– LOAD THE VENDER – (Cont.)

OPERATIONAL CHECKS

1. Plug service cord into outlet with correct voltage. (See serial number plate.) Do Not use extension cords with less than 16 guage wire.
2. The vender must be grounded. If 3 prong outlet is available, plug vender directly into outlet. If 3 prong outlet is not available, plug the vender into 2 prong outlet, using 2 prong adapter. Be sure to ground "pigtail" on adapter.
3. Make sure that nothing obstructs air intake at bottom of door. Check rear of cabinet occasionally to be sure that exhaust is not blocked by waste paper, etc.

CARE AND MAINTENANCE

1. Exterior cleaning. Wash cabinet periodically with soap and water. Wax often, using a good automotive wax.
2. If corrosion occurs on cabinet interior, rub it off with fine steel wool and paint over spot with aluminum paint, or zinc rich.
3. Keep condenser clean. Use brush or vacuum cleaner to remove dust accumulation from condenser.

PROPER SELECTION

Selections on the front door selector panel are as in sketch below:

See stack numbering sequence on inside of vender.



WHAT TO DO WHEN YOU GET A NEW VENDER (Cont.)

– CHECK IT OUT –

WHAT TO DO	WHAT SHOULD HAPPEN	WHAT SHOULDN'T HAPPEN
<p>Plug the supply cord in, close the vender door.</p> <p>Put in correct change.</p> <p>Load the money tubes and put a quarter into the vender.</p> <p>Fully load the vender with warm cans or bottles and let it run over night, then vend a can or bottle from each vend stack.</p>	<p>The compressor runs. The condenser fan runs. The evaporator fan runs. "Correct change only" window lights.</p> <p>Push the select button to dispense a can or bottle.</p> <p>A can or bottle may be dispensed from the vend stack and correct change is returned.</p> <p>The first can or bottle vended has a temperature of 32° to 34° F.</p>	<p>The refrigerant lines rattle.</p> <p>Some cans or bottles are frozen or the next to be vended cans or bottles are above the temperature of 38°F.</p>

– PUT IT TO WORK –

SPACE NEEDED

Size of the working space needed around the vender is shown on the title page of this manual. DO NOT block the rear of the vender. Keep the vender 4 inches from the wall to provide adequate ventilation for the condenser. Make sure that nothing obstructs air intake at the bottom of the door.

WHAT TO DO WHEN YOU GET A NEW VENDER (Cont.)**– PUT IT TO WORK – (Cont.)****LEVEL THE VENDER**

Level the vender. When the vender is level then the door can be opened to any position and it will not move by itself. Try it half closed, straight open and wide open before you decide that the vender is level.

Make sure that all of the leveling screws are touching the floor.

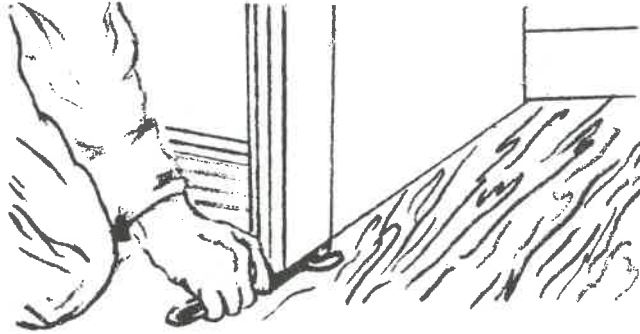

Level The Vender

ELECTRIC POWER NEEDED

Look at the serial number plate on the right side to find out what the vender's power needs are. Be sure that the vender gets the right power.

The vender uses 115 volts single phase, either 50 or 60 cycle, alternating current. The voltage must never be lower than 90 or above 125.

GROUND THE VENDER

This vender is made with a three prong plug on the supply cord. It grounds when the plug is put into a three prong outlet. If there is no prong outlet near the vender, use a two prong adapter. If a two prong adapter is used, make sure the adapter's ground wire is connected to a good ground.

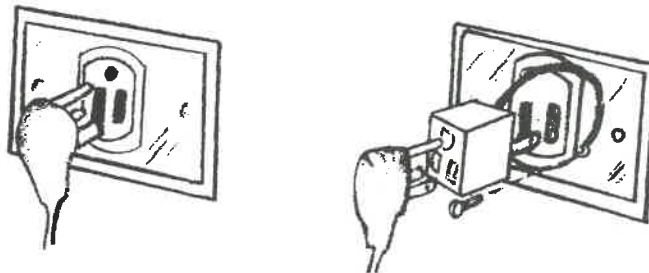

Ground The Vender

**HOW THE VENDING MECHANISM WORKS
– ELECTRICAL PARTS –**

CORRECT CHANGE LAMP

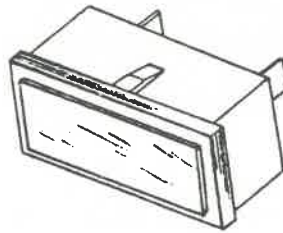

Correct Change Lamp

The correct change lamp is mounted in the coin insert casting and is retained by projections top and bottom.

The correct change lamp is in the coin tube switch circuit and is "ON" when coins are in the tube.

SELECT SWITCH NO. 1, 2, 3, 4, 5 & 6

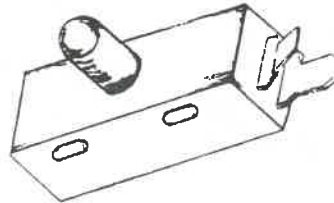

Select Switch

The select switch is located in the selector panel behind the push button and is secured with two (2) screws.

The N.O. contact of the Select Switch is in the Vend Motor Coil and the Sold Out Lamp circuits. This N.O. contact closes and completes the Vend Motor Coil Circuit and the Sold Out Lamp Circuit.

The N.C. contact of the Select Switch is in the Vend Motor Coil Circuits. This N.C. contact opens in the Select Panel Circuit.

LAMP SOLD OUT SWITCH 1, 2, 3, 4, 5 & 6

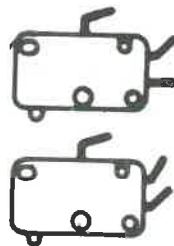

Lamp Sold Out Switch

The lamp sold out switch (one for each vending circuit) is located near the bottom of the column at the front and is fastened with screws.

The N.C. contact of the (lamp) sold out switch is in the Vend Relay Coil Circuit and the Coin Changer Magnet Circuit. This N.C. contact (kept closed by can or bottle) is in parallel with all of the other N.C. contacts of the Lamp Sold Out Switches and when all are open, the coin changer magnets are turned off and the changer will not accept coins.

The N.O. contact of the (Lamp) sold out switch is in the sold out lamp circuit (kept open by can or bottle). When not kept open by can or bottle, this N.O. contact closes and completes the sold out lamp circuit.

HOW THE VENDING MECHANISM WORKS (Cont.)

– ELECTRICAL PARTS – (Cont.)–

SOLD OUT LAMPS



Sold Out Lamp

The sold out lamp (one for each vending circuit) is secured to the back of the select button in the Selector Panel.

The sold out lamp is turned on by the closing of the N.O. contacts of the lamp sold out switch.

COIN VEND SWITCH (Coin Changer)

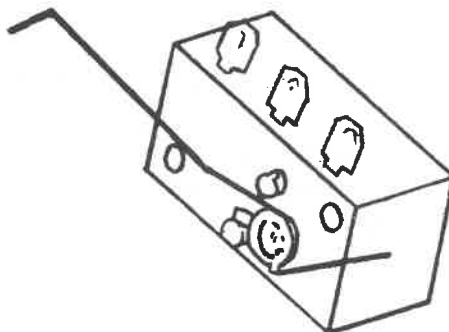

Coin Vend Switch

The coin vend switch is located below the slug rejector and is fastened to the coin changer housing with two (2) screws and nuts.

The N.O. contact of the coin vend switch is in the vend relay coil and the coin changer magnet circuits. This N.O. contact closes and completes the vend relay coil circuits.

The N.C. contact of the coin vend switch is in the select relay coil circuits. This N.C. contact closes in the select relay coil circuits to set up these circuits so that a selection can be made.

HOW THE VENDING MECHANISM WORKS (Cont.)

– ELECTRICAL PARTS – (Cont.)

VEND SOLD OUT SWITCH 1, 2, 3, 4, 5 & 6

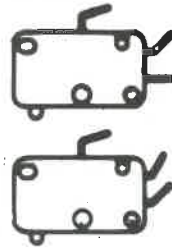

Sold Out Switch

The vend sold out switch (one for each vending circuit) is located on a bracket at the base of each vend stack.

The N.O. contact of the vend sold out switch is in the Vend Motor Circuit. This N.O. contact (held closed by can or bottle) stays closed in the vend motor circuit so the Vend Motor Circuit can be completed.

HOW THE VENDING MECHANISM WORKS (Cont.)

ELECTRICAL PARTS (Cont.)

VEND MOTOR

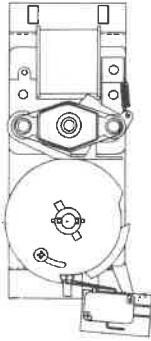

For Narrow Column

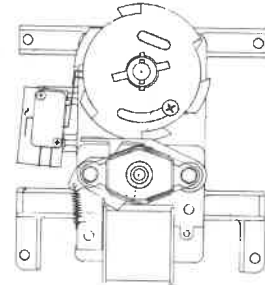

For Standard Column

VEND MOTOR

The vend motor (one for each vending stack) is mounted on a bracket at the front of the vender.

The vend motor is in the vend motor coil circuit. The vend motor runs when a N.O. select switch (pushed) closes and completes the vend motor circuit. The vend motor continues to run through the N.C. contact (worked by the vend motor cam) of the cam hold switch. The vend motor stops when the vend motor switch arm drops off of the high side of the vend motor cam.

MAGNETS (Coin Changer)

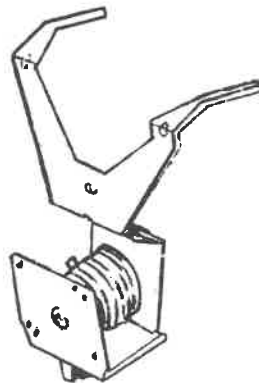

Coin Return Magnet

The magnets are in the coin changer behind the coin rejector.

The magnets N.O. and N.C. are in the Vend Realy Coil Circuit. The coin changer magnet are turned off when the N.C. Vend Relay Switch No. 1 opens and breaks the coin changer magnet circuit.

HOW THE VENDING MECHANISM WORKS (Cont.)

ELECTRICAL PARTS (Cont.)

VEND MOTOR SWITCH

- A. Is Vend Motor Switch
- B. Is Cam-Hold Switch
- C. Is By-Pass Switch

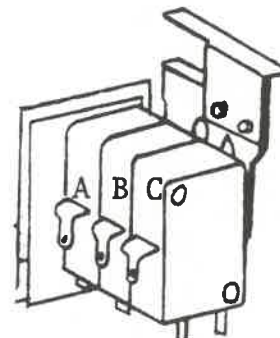

The Vend Motor, the Cam-Hold and the By-Pass switches are together and do not come apart. The Vend Motor Switch, one (1) for each circuit, is located on the Vend Motor Assembly secured by two (2) screws.

The N.C. contact of the Vend Motor Switch is in the Coin Changer Circuit. This N.C. contact opens in the Coin Changer Circuit.

The N.O. contact of the Vend Motor Switch is in the Vend Motor Coin Circuit. This N.O. contact closes in the Vend Motor Coil Circuit to keep the Vend Motor running until the arm of the Vend Motor Switch drops into the cam notch and the Vend Motor stops.

CAM HOLD SWITCH

The Vend Motor, Cam-Hold and the By-Pass switches are together and do not come apart. The Cam-Hold switch, one (1) for each circuit, is located on the Vend Motor Assembly secured to a bracket by two (2) screws. This is in the vend motor circuit.

The N.O. contact of the Cam-Hold switch (held closed by the vending cam) is in the Vend Motor circuit. Shortly after the beginning of the vending cycle the arm of the switch (worked by the vending cam) drops into the cam notch and this N.O. contact opens in the circuit to the Select Panel.

When the arm of the switch reaches top side of cam this N.O. contact closes in the circuit to the Select Panel and is still closed at end of the vending cycle.

When the arm of the switch drops into the cam notch, the N.C. contact closes in the Vend Motor Coil Circuit to keep the Vend Motor running. When the arm of the switch reaches top side of cam, this N.C. contact opens in the Vend Motor circuit and is still open at end of the vending cycle.

BY-PASS SWITCH

The Vend Motor, the Cam-Hold and the By-Pass switches are together and do not come apart. The By-Pass Switch, one (1) for each circuit, is located on the Vend Motor Assembly secured by two (2) screws. This switch is a by-pass around the Vend Motor Switch to keep the Coin Changer circuit closed if the Vend Motor stops or is stopped when the arm of the Vend Motor Switch is top side of the vending cam, ie, all other vending circuits are operative.

HOW THE VENDING MECHANISM WORKS (Cont.)**ELECTRICAL PARTS (Cont.)****BY-PASS SWITCH (Cont.)**

The N.O. contact of the By-Pass Switch, there is no N.C. (held closed by the vending cam), is in the Coin Changer Circuit. Shortly after the beginning of the vending cycle, the arm of the switch (worked by the vending cam) drops into the Cam notch and this N.O. contact opens in the Coin Changer Circuit. When the arm of the switch reaches top-side of cam this N.O. contact closes in the Coin Changer circuit and is still closed at end of the vending cycle.

VEND RELAY**VEND RELAY SWITCH NO. 1 N.C. (There is no N.O.)**

The N.C. contact of Vend Relay Switch No. 1 is the Coin Changer Circuit. This N.C. contact opens and breaks the Coin Changer Magnet Circuit.

VEND RELAY SWITCH NO. 2 N.O. (There is no N.C.)

The N.O. contact of Vend Relay Switch No. 2 is in each of the Vend Motor Coil Circuits. This N.O. contact closes in the Vend Motor Coil Circuits to set up these circuits so that a selection can be made.

VEND RELAY NO. 3 N.O. (There is no N.C.)

The N.O. contact of Vend Relay Switch No. 3 is in the Vend Relay Coil Circuit. This N.O. contact closes in and keeps the Vend Relay Coil Circuit completed.

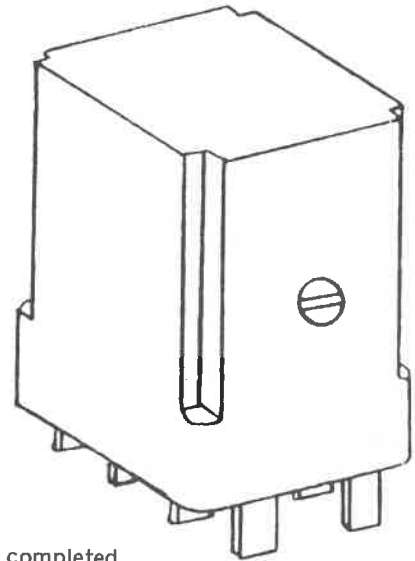

HOW THE VENDING MECHANISM WORKS (Cont.)

**VENDING CYCLE AND
Study-
ACROSS THE LINE WIRING DIAGRAM**

Study the written vending cycle beginning on Page 47 in connection with the across the line wiring diagram. The Across the Line Wiring Diagram can serve as an excellent "trouble shooting chart."

Example: Vender accepts coin.
Vend relay is energized but immediately "pops" out.

Do this: Look at Across The Line Wiring Diagram and locate:

1. coin vend switch

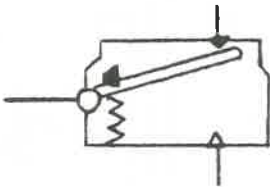

2. vend relay

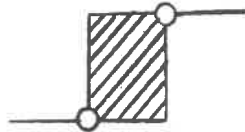

3. vend relay switch No. 1

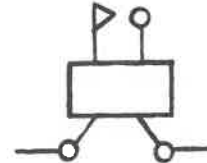

- Observations:
1. Vend relay coil is the affected circuit.
 2. N.O. coin vend switch is in the vend relay coil circuit.
 3. N.O. Vend Relay Switch No. 1 is also in the vend relay coil circuit.
 4. N.O. Vend Relay Switch No. 1 is the "holding switch" for this circuit.

- Conclusions:
1. N.O. Vend Relay Switch No. 1 did not "hold" or keep the circuit closed.

WHY:

- Check:
1. Gap between contacts (too far apart).
 2. Dirt between contact.
 3. Weak coil on Vend Relay.

HOW THE VENDING MECHANISM WORKS (Cont.)

*- VEND CYCLE - (Cont.)

WHAT DOES IT	WHAT HAPPENS
<p>The Vending Cam A coin</p>	<p>Pushes the coin vend switch arm down and;</p>
<p>The N.O. contact of the coin vend switch</p>	<p>Closes and completes the vend relay coil circuit.</p>
<p>The Vend Relay Coil</p>	<p>Closes the N.O. contact of Vend Relay Switch #3 in the Vend Relay Coil Circuit and at the same time,</p> <p>Opens the N.C. contact of Vend Relay Switch No. 1 in the Coin Changer Magnet Circuit and at the same time,</p> <p>Closes the N.O. Contact of vend relay switch No. 2 in the vend motor coil circuits and closes & completes the sequence relay coil circuit.</p>
<p>A spring (in the coin vend switch)</p>	<p>Pulls the vend switch arm back up and,</p>
<p>The N.C. contact of the coin vend switch</p>	<p>Closes in the Vend motor coil circuit,</p>
<p>The customer</p>	<p>Pushes a select button</p>
<p>The select button</p>	<p>Works the N.O. contact of the select switch</p>
<p>The N.O. contact of the select switch</p>	<p>Closes and completes the vend motor coil and the sold out lamp circuit, and</p>
<p>The vend motor</p>	<p>Starts to run and at the same time,</p>
<p>The N.C. contact of the select switch</p>	<p>Opens in the select panel circuit, and at the same time</p>
<p>The Vending Cam</p>	<p>Works the arm of the cam hold switch - - - the arm drops into the cam's notch</p>
<p>The N.O. contact of the Cam Hold Switch (held closed by cam)</p>	<p>Opens in the Select Panel Circuit and opens and breaks the Sequence Relay Coil circuit and at the same time,</p>
<p>The N.C. contact of the Cam Hold switch</p>	<p>Closes in the Vend Motor Coil Circuit to keep the motor turning and at the same time ,</p>

* Refer to Across the Line Wiring Diagram: C7300.05 or D7220.05

HOW THE VENDING MECHANISM WORKS (Cont.)

*- VEND CYCLE - (Cont.)

WHAT DOES IT	WHAT HAPPENS
The Vending Cam	Works the arm of the by-pass switch - - - the arm drops into the cam's notch and,
The N.O. contact of the by-pass switch (held closed by cam)	Opens in the Coin Changer Circuit and,
The Vending Cam	Works the arm of the vend motor switch - - - the arm rises to high side of cam and
The N.O. contact of the Vend Motor Switch	Closes in the Vend Motor Coil Circuit to keep the Vend Motor running and at the same time
The N.C. contact of the Vend Motor Switch	Opens and breaks the vend relay coil circuit and,
The N.O. contact of Vend Relay Switch #3	Opens in the vend relay coil circuit and at the same time,
The N.C. contact of Vend Relay Switch #1	Closes in the Coin Changer circuit and the arm of the by-pass switch and the cam hold switch ride to high side of cam and,
The N.O. contact of Vend Relay Switch #2	Opens in the Vend Motor Coil Circuits and rapidly thereafter
The N.O. contact of the by-pass switch	Closes in the Coin Changer Circuit and at the same time.
The N.O. contact of the Cam hold switch	Closes in the Select Panel Circuit and at the same time.
The N.C. contact of the Cam hold switch	Opens in the Vend Motor Coil Circuit and,
The Vending Cam	Continues to work the arm of the vend motor switch and the arm drops into the cam notch and
The N.O. contact of the Vend Motor Switch	Opens and breaks the Vend Motor Coil Circuit - - - the Motor stops and the oscillator stops and,
The N.C. contact of the Vend Motor Switch	Closes in the Coin Changer Circuit.

*Refer to Across the Line Wiring Diagram: C7300.05 or D7220.05

HOW TO TAKE CARE OF THE VENDER

– WHAT TO CLEAN –

CABINET

Wash the vender exterior with either soap and warm water or a good detergent and warm water.

Wash all plastic parts with a mild soap and warm water.

The vender should be waxed often with a good grade of automobile wax.

Any corrosion inside the vender should be removed with fine steel wool and the area should be painted with aluminium paint.

Keep the condenser clean.

SLUG REJECTOR

Use a clean cloth to remove loose dirt. A dirty rejector should be cleaned with hot water and a good detergent. Dry it with a clean cloth.

Lubricate only the moving parts of the slug rejector. Oil should not be used on these moving parts.

– WHEN AND WHAT TO LUBRICATE –

HOW OFTEN	PART	LUBRICANT
Every six months	Main Door	Mechanics Friend
	1. Lock bolt and nut retainer	Mechanics Friend
	2. Hinge pivot points	Slipicone
Every year	3. Door gasket, hinge side	
Every six months	Inner Door	Mechanics Friend
	1. Latch assembly	Mechanics Friend
	2. Hinge pivot points	

HOW TO TAKE CARE OF THE VENDER (Cont.)

– THINGS TO ADJUST – (Cont.)

TEMPERATURE CONTROL – Ranco No. A12-1558
 Cutler Hammer No. 9531N43

This is a "Constant Cut In" type of control which has two (2) adjustments: They are:

1. The temperature control cam on the outside of the temperature control box.
2. The inside range screw which is under the fibre cover of the temperature control box of the RANCO, and on the side wall of the Cutler Hammer (near terminal cover).

NOTE: The differential screw located between the terminals of the control is sealed and MUST NOT BE CHANGED.

As to No. 1 Adjustment:

The temperature control cam is set in an approximate neutral position. It can be used to make cut out temperature colder by turning the cam clockwise - or - to make the cut out temperature warmer by turning the cam counter clockwise. When the cam is used the cut in temperature (which governs the defrost) remains constant.

As to No. 2 Adjustment:

The inside range screw or screws are used for the altitude adjustment, see altitude below. This screw adjusts both the cut out and cut in settings on the RANCO. It may also be used for colder temperatures by turning the screw counter clockwise or warmer by turning screw clockwise.

On the Cutler Hammer there are two (2) screws provided, one (1) for cut in and one (1) for cut out, both must be adjusted for altitude corrections. For temperature adjustment, turn screws clockwise for colder and counter clockwise for warmer. When adjusting for temperature DO NOT TURN more than 1/8 of a turn at a time. Let the machine run over night before making further adjustment.

TEMPERATURE CONTROL ALTITUDE ADJUSTMENT

Control is factory set at altitude of 500 ft. For higher altitudes, control should be adjusted to prevent freeze-up of product. Adjust inside range screw as follows:

ALTITUDE FT;	RANCO SCREW CLOCKWISE	CUTLER-HAMMER BOTH SCREWS COUNTER-CLOCKWISE
2000	¼ turn	1/8 turn
4000	½ turn	¼ turn
6000	¾ turn	½ turn
8000	1 turn	5/8 turn

HOW TO TAKE CARE OF THE VENDER (Cont.)

- THINGS TO ADJUST - (Cont.)

TEMPERATURE CONTROL

RANCO

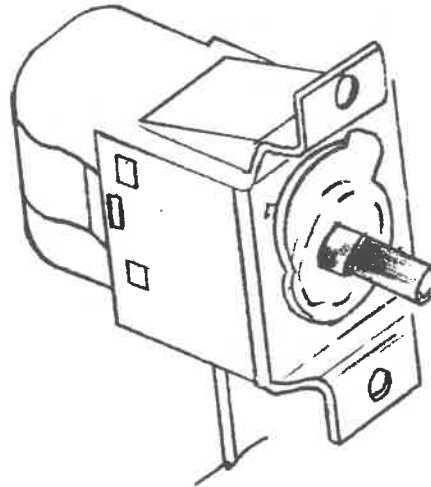
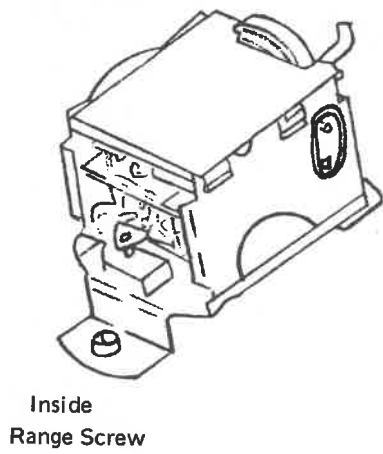

Outside Range Screw

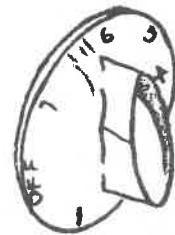

CUTLER - HAMMER

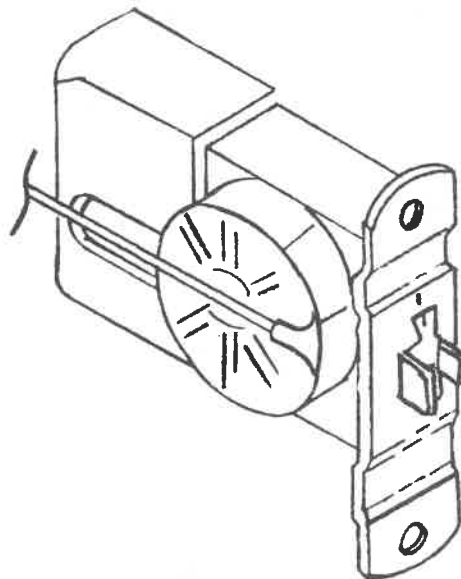
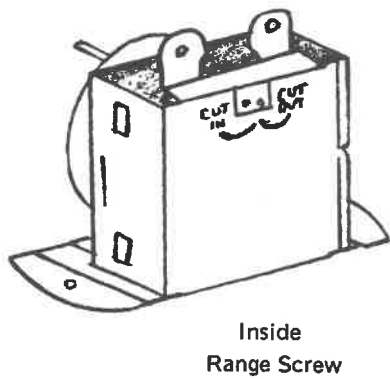

Outside Range Screw

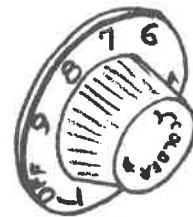

HOW TO TAKE CARE OF THE VENDER (Cont.)

- THINGS TO ADJUST - (Cont.)

**BOTTLE AND CAN ADJUSTMENTS
STANDARD COLUMN
LOADING INSTRUCTIONS**

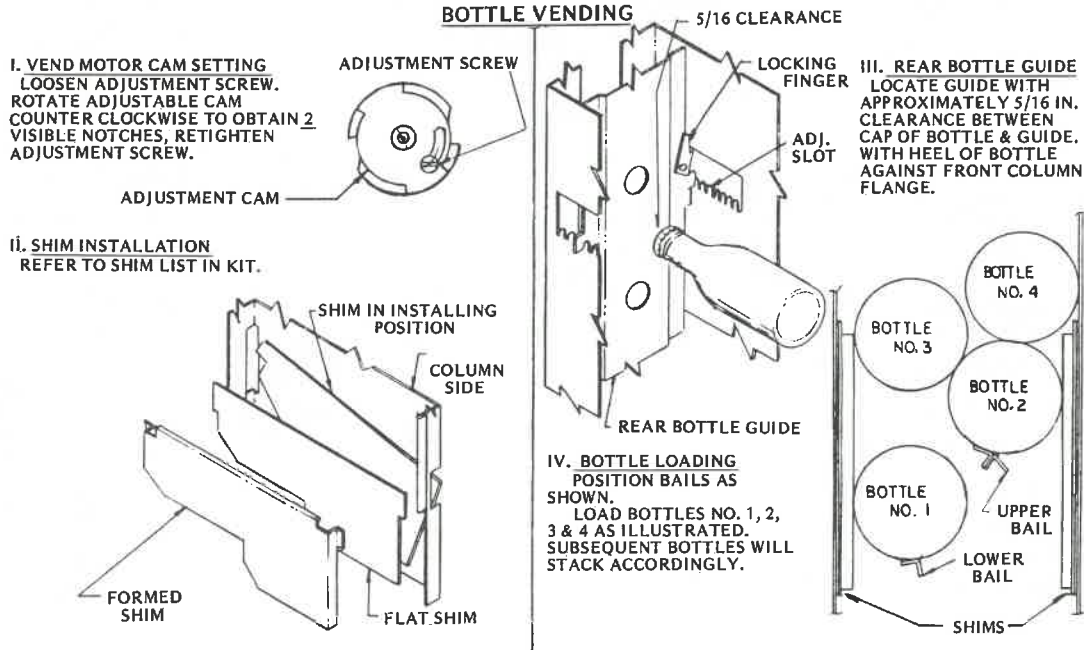

FIG. 1

**STANDARD COLUMN
LOADING INSTRUCTIONS**

12 OZ. CAN VENDING

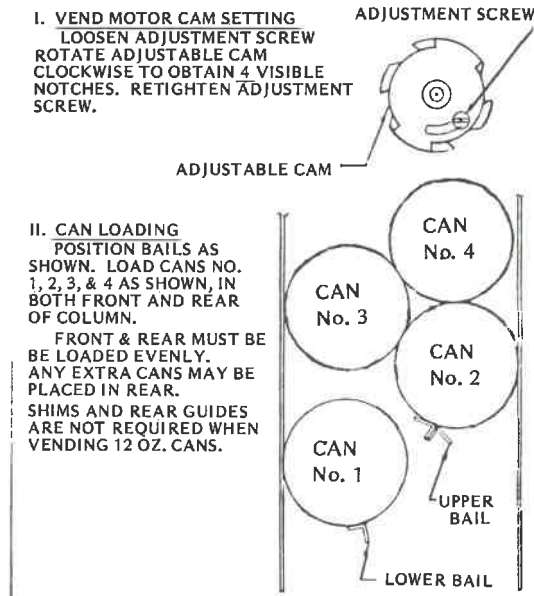

FIG. 2

- THINGS TO ADJUST - (Cont.)

BOTTLE AND CAN ADJUSTMENTS

NARROW COLUMN

BOTTLE VENDING

I. VEND MOTOR CAM SETTING
 LOOSEN ADJUSTMENT SCREW.
 ROTATE ADJUSTABLE CAM
 CLOCKWISE TO OBTAIN 1
 VISIBLE NOTCH. TIGHTEN
 ADJUSTMENT SCREW.



II. REMOVE EXISTING CAN SHIMS

III. BOTTLE SHIM INSTALLATION
 REFER TO SHIM LIST IN KIT.

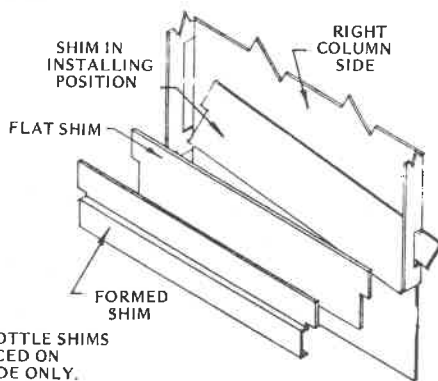

IV. REAR BOTTLE GUIDE INSTALLATION

SEE ILLUSTRATION OF WIDER COLUMN LOADING INSTRUCTIONS. LOCATE GUIDE WITH APPROXIMATELY 5/16 IN. CLEARANCE BETWEEN CAP OF BOTTLE & GUIDE, WITH HEEL OF BOTTLE APPROXIMATELY 1/2 IN. FROM FRONT COLUMN FLANGE.

V. BOTTLE ROD INSTALLATION
 POSITION ROTOR AS SHOWN
 AT LEFT BELOW. REFER TO
 BOTTLE ROD LIST IN KIT.

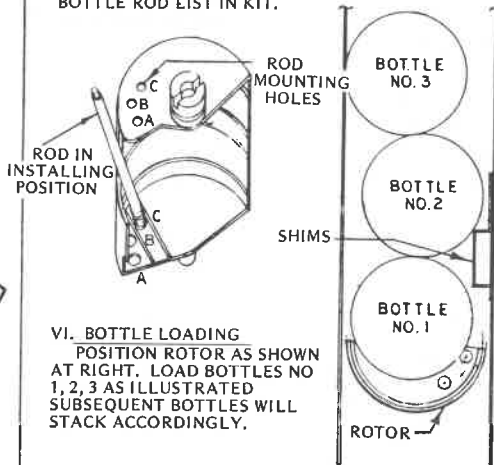

VI. BOTTLE LOADING
 POSITION ROTOR AS SHOWN
 AT RIGHT. LOAD BOTTLES NO
 1, 2, 3 AS ILLUSTRATED
 SUBSEQUENT BOTTLES WILL
 STACK ACCORDINGLY.

FIG. 3

LOADING INSTRUCTIONS

NARROW COLUMN

12 OZ. CAN VENDING

I. VEND MOTOR CAM SETTING
 LOOSEN ADJUSTMENT SCREW.
 ROTATE ADJUSTABLE CAM
 CLOCKWISE TO OBTAIN 2
 VISIBLE NOTCHES. TIGHTEN
 ADJUSTMENT SCREW.



II. CAN SHIM INSTALLATION

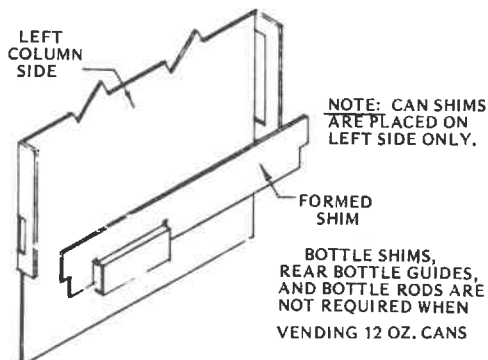

III. CAN LOADING
 POSITION ROTOR AS
 SHOWN BELOW. LOAD CANS
 NO. 1, 2, & 3 AS ILLUSTRATED,
 IN BOTH FRONT AND REAR
 OF COLUMN. FRONT AND
 REAR MUST BE LOADED
 EVENLY. ANY EXTRA CANS
 MAY BE PLACED IN REAR.

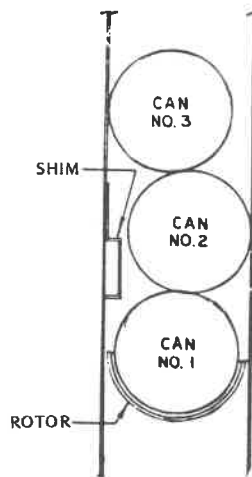

FIG. 4

HOW TO TAKE CARE OF THE VENDER (Cont.)

THINGS TO ADJUST (Cont.)

BOTTLE AND CAN ADJUSTMENTS (Cont.)

Shim Requirements

<u>RETURNABLE BOTTLES</u>	<u>WIDE COLUMN</u>		<u>NARROW COLUMN</u>		<u>RODS REQUIRED</u>
	<u>SHIMS REQ'D</u>		<u>SHIMS REQ'D</u>		
	<u>EACH SIDE OF COL.</u>		<u>RIGHT SIDE</u>		
	<u>FORMED</u>	<u>FLAT</u>	<u>FORMED</u>	<u>FLAT</u>	
6 1/2 oz. Coca-Cola	1	2	1	4	1 in A*, 1 in C
6 1/2 oz. Dr Pepper	1	4	1	4	1 in A*, 1 in C
7 oz. Sprite, Tab, Fanta	1	1	1	4	1 in A*, 1 in C
7 oz. Seven-Up	1	3	Use Wide Columns		-----
8 oz. Nu Grape	1	5	1	4	1 in A*, 1 in C
8 oz. Pepsi-Cola	1	1	1	4	1 in A*, 1 in C
10 oz. Nehi	1	3	1	4	1 in A*, 1 in C
10 oz. Coca-Cola	1	1	1	4	1 in A*, 1 in C
10 oz. Sprite, Tab, Fanta	1	1	1	4	1 in A*, 1 in C
10 oz. Pepsi	1	1	1	4	1 in A*, 1 in C
10 oz. Dr Pepper	1	1	1	4	1 in A*, 1 in C
10 oz. Seven-Up	1	1	1	4	1 in A*, 1 in C
10 oz. Royal Crown Cola	1	1	1	4	1 in A*, 1 in C
10 oz. Diet Dr Pepper	1	1	1	4	1 in A*, 1 in C
10 oz. Diet Rite Cola	1	1	1	4	1 in A*, 1 in C
12 oz. Coca-Cola	0	0	1	0	1 in B
12 oz. Sprite, Tab, Fanta	0	0	1	0	1 in B
12 oz. Royal Crown Cola	0	0	1	0	1 in B

<u>NON-RETURNABLE BOTTLES</u>	<u>WIDE COLUMN</u>		<u>NARROW COLUMN</u>		<u>RODS REQUIRED</u>
	<u>SHIMS REQ'D</u>		<u>SHIMS REQ'D</u>		
	<u>EACH SIDE OF COL.</u>		<u>RIGHT SIDE</u>		
	<u>FORMED</u>	<u>FLAT</u>	<u>FORMED</u>	<u>FLAT</u>	
10 oz. Coca-Cola B Bottle	0	3	1	2	1 in B
10 oz. Coca-Cola C Bottle	1	0	1	2	1 in B
10 oz. Dr Pepper (Embossed Label)	1	0	1	2	1 in B
10 oz. Seven-Up (Embossed Label)	1	0	1	2	1 in B
10 oz. Pepsi-Cola (Embossed Label)	1	0	1	2	1 in B
10 oz. Paper Label 2 3/8" Dia. 7 3/4" High	1	0	1	4	1 in A*, 1 in C
10 oz. Mountain Dew	1	0	1	2	1 in B
10 oz. Sprite C Bottle	1	0	1	2	1 in B
10 oz. Tab C Bottle	1	0	1	2	1 in B
10 oz. Fresca C Bottle	1	0	1	2	1 in B
10 oz. Crass Orange C Bottle	1	0	1	2	1 in B
10 oz. Tropicana Fruit Drink	0	2	1	0	1 in B
10 oz. Sprite B Bottle	0	3	1	2	1 in B
10 oz. Tab B Bottle	0	3	1	2	1 in B
10 oz. Fresca B Bottle	0	3	1	2	1 in B
10 oz. Mello Yello B Bottle	0	3	1	2	1 in B
10 oz. Crass Orange B Bottle	0	3	1	2	1 in B
16 oz.	Contact Dixie-Narco				

***SLIDE 17/32" OD PLASTIC TUBING ON "A" ROD BEFORE INSTALLING. PULL BACK TOWARDS HEEL OF BOTTLE AFTER ROD IS IN PLACE.**

HOW TO TAKE CARE OF THE VENDER (Cont.)

THINGS TO ADJUST (Cont.)

BOTTLE AND CAN ADJUSTMENTS (Cont.)

NARROW COLUMNS ONLY (BOTTLES)

Any time Narrow Columns sell out, load first 3 bottles Heel down - Crown Up - At approximately 45° - Then release to horizontal position.



NOTE: Install Plastic Tubing Only Where Called Out.

BOTTLE LENGTH

THE CLOSURE STRIP AND DISCHARGE MEMBER ARE SET FOR MAXIMUM SECURITY WHEN VENDING CANS. TO VEND BOTTLES REFER TO INSTRUCTIONS BELOW.

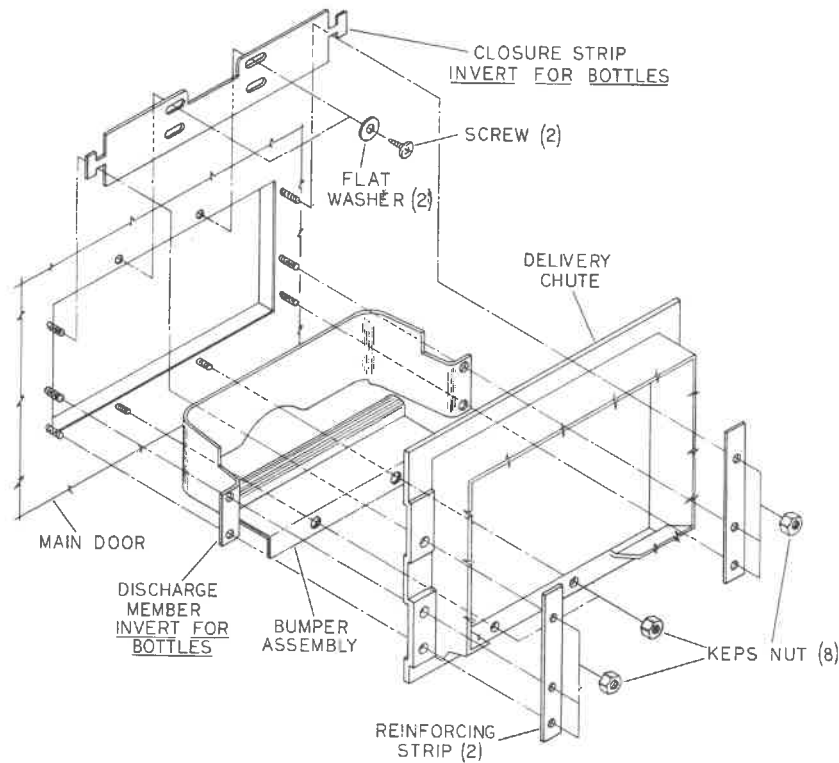

FIG. 1

The closure strip and discharge member are set for maximum security when vending Cans. To Vend Bottles refer to instructions above.

HOW TO TAKE CARE OF THE VENDER (Cont.)

– THINGS TO ADJUST – (Cont.)

BOTTLE AND CAN ADJUSTMENTS (Cont.)

ADJUSTMENT SOLD OUT SWITCHES

The assembly of the front sold out switches is so designed as to provide two (2) different levels of sold out conditions. By removing the cover, the mounting plate supporting the sold out switches can be adjusted to allow the following number of containers to remain in each column when sold out occurs.

Lowest position	1 bottle	2 cans
Second position	2 bottles	4 cans

HOW TO CORRECT COMMON VENDING TROUBLES

-- REJECTS ALL GOOD COINS --

A POSSIBLE CAUSE IS	TO MAKE SURE	THIS IS WHAT TO DO
Vendor not plugged in	Look, if not	Plug the vender in.
Slug rejector is neither vertical nor level.	Look at it and try a coin. If coin is rejected,	Level the vender.
Blocking fingers remain in coin path.	Remove the Slug Rejector - unplug the vender. Touch prods of test lamp to either side of electro magnet coil, lamp should light, if it doesn't,	Put in a new coil or magnet coil assembly.
The coin paths are dirty	Remove the slug rejector,,look at it, if it is dirty,	Clean it with warm water, a good detergent. Dry it thoroughly.
The slug rejector is out of adjustment or the scavenger gate is not closed.	Remove the slug rejector. Put a coin in, if it rejects the coin,	Adjust the slug rejector.
Low voltage.	Check with a volt-meter, if voltage is low,	Correct with location outlet.
N.C. contact of Vend Relay Switch #1.	Put prods of test lamp to N.C. and C. contact. Lamp should light, if it doesn't,	Clean contact with approved cleaner or install new relay.
*N.O. contact of By Pass Switch and	Push switch arm back - put prods of test lamp to N.O. and C. contact Lamp should light, if it doesn't,	Replace switch.
*N.C. contact of Vend Motor Switch.	Put prods of test lamp to N.C. and C. contact. Lamp should light, if it doesn't,	Replace Switch.

*These two (2) switches combined and in the same circuit can break the circuit to the Coin Changer.

HOW TO CORRECT COMMON VENDING TROUBLES (Cont.)

— ACCEPTS COINS BUT DOES NOT LET A CAN OR BOTTLE VEND FROM ANY COLUMN —

A POSSIBLE CAUSE IS	TO MAKE SURE	THIS IS WHAT TO DO
Vend Switch Coin Changer.	Put the prods of a test lamp to N.C. and C. contacts. Lamp should light, if it doesn't,	Put in a new Vend Switch.
Vend Switch Coin Changer.	Put the prods of a test lamp to N.O. and C. contacts. Push the switch arm down, lamp should light, if it doesn't,	Put in a new Vend Switch.
Vend Relay Coil.	Put the prods of a test lamp to either side of the coil. Lamp should light, if it doesn't,	Put in a new Vend Relay.
N.O. contact of Vend Relay Switch #2.	Energize Vend Relay Coil. If contact does not touch or if it touches but still inoperative,	Clean contact with approved cleaner or put in new relay.
N.C. contact of Select Switch #5.	Put the prods of a test lamp to N.C. and C. contacts. Lamp should light, if it doesn't,	Put in a new Select Switch.
N.O. contact of any cam hold switch.	Push switch arm back. Put prods of test lamp to N.O. and C. Lamp should light, if it doesn't,	Put in a new Cam hold Switch.
N.O. contact of Vend Relay Switch #3.	Energize Vend Relay Coil. If contact does not touch or it touches and then opens,	Clean contact with approved cleaner or put in new relay.

HOW TO CORRECT COMMON VENDING TROUBLES (Cont.)

DIXIE-NARCO

— ACCEPTS COINS BUT DOES NOT LET A CAN OR BOTTLE VEND FROM A GIVEN COLUMN —

A POSSIBLE CAUSE IS	TO MAKE SURE	THIS IS WHAT TO DO
Vend Motor.	Put the prods of a test lamp to either side of the coil. Lamp should light, if it doesn't,	Put in a new vend motor.
N.O. contact of Vend Motor Switch.	Push switch arm back. Put the prods of a test lamp to N.O. and C. contacts. Lamp should light, if it doesn't,	Put in a new vend motor switch.
N.O. contact of Ven N.O. contact of Vend Motor Switch.	Put the prods of a test Lamp to N.O. and C. contacts. Lift switch arm up, lamp should light, if it doesn't,	Put in a new switch.
N.O. contact of a Select Switch.	Push switch arm back. Put the prods of a test lamp to N.O. and C. contacts. Lamp should light, if it doesn't,	Put in a new switch.
N.C. contact of a Sold Out Switch in a Vending Circuit.	Put the prods of a test lamp to N.C. and C. contacts. Lamp should light, if it doesn't,	Put in a new switch.
N.C. contact Coin Vend Switch.	Put the prods of a test lamp to N.C. and C. contacts. Lamp should light, if it doesn't,	Put in a new Vend Switch.
N.O. contact of Vend Relay Switch #2.	Energize Vend Relay Coil. If contact does not touch or if it touches and then opens,	Clean contact with "Cobehn" or put in new relay.

HOW THE REFRIGERATION SYSTEM WORKS

– MECHANICAL PARTS –

COMPRESSOR MOTOR

The compressor motor (sealed in the compressor housing) drives the compressor with a shaft that is shared by both parts.

COMPRESSOR

The compressor (sealed in the compressor housing) sucks cold, low pressure freon gas from the evaporator and pumps hot, pressure freon gas out to the condensor.

CONDENSER

The condenser, located in the base of the vender, at the front, takes heat out of the hot, high pressure gas that comes from the compressor. The gas loses heat as it goes through the condenser coils, and changes into a liquid because it is still under high pressure.

CONDENSER FAN

The condenser fan (between the condenser and motor compressor) first sucks air from the outside of the vender through the condenser. This air takes heat from the condenser first and then is blown over the compressor housing from which it also takes heat before going back outside of the vender. The condenser fan runs when the motor compressor runs.

MOLECULAR STRAINER DRYER

The molecular strainer dryer is in the liquid line between the condenser and the capillary tube. This dryer traps and holds water molecules but lets oil molecules and freon molecules go through into the capillary tube.

CAPILLARY TUBE

The capillary tube (between the condenser and the evaporator in the refrigerant line) has a very small inside diameter, so the flow of the liquid freon from the condenser into the evaporator is slow, but steady, even with the pressure the compressor builds up in the condenser. This helps to keep the pressure in the evaporator low.

HOW THE REFRIGERATION SYSTEM WORKS (Cont.)

– ELECTRICAL PARTS – (Cont.)

EVAPORATOR

The evaporator (in the vender cabinet) takes heat from the air in the vender cabinet and gives this heat to the liquid refrigerant. The liquid refrigerant is evaporated (boiled off) as a gas, and the gas is sucked out by the compressor and so the pressure is kept low.

EVAPORATOR FAN

The evaporator fan sucks warm air from around the cans or bottles in the cooling compartment and blows it across the evaporator. As the air goes across the evaporator, it gives up heat to the evaporator. As the air goes across the evaporator, it gives up heat to the evaporator, then goes back to the cans or bottles, and takes heat from them. This fan runs all the time when the vender is plugged in.

CONDENSATE PAN

The condensate pan (located in the compressor compartment) collects the water which runs from the vender during the defrost cycle. The water is evaporated into the surrounding air by means of soakers, and the air movement resulting from the condenser fan blade rotation. The soakers extend down into the pan to absorb the water. Exposure to the surrounding air vaporizes the water in the soakers, and the water vapor is carried into the air by the action of the condenser fan blade.

– ELECTRICAL PARTS –

TEMPERATURE CONTROL

The temperature control is the name of a part that is made up of a control bulb connected by a small metal tube to a bellows. The control bulb is in a tube back of the evaporator. The bellows and a switch known as the temperature control switch are in the temperature control box which is fastened to the right side inside the vender.

The control bulb and the bellows have a vapor in them. When the temperature of the vapor in the bulb rises, it builds up pressure in the bellows tube. This pushes the bellows out, makes it longer. When the control bulb is cool the vapor shrinks back, and the bellows pull in and get shorter. These movements of the bellows work the switch — called the temperature control switch — closing it when the bulb is heated and opening it when the bulb is cooled.

HOW THE REFRIGERATION SYSTEM WORKS (Cont.)

– ELECTRICAL PARTS – (Cont.)

TEMPERATURE CONTROL (Cont.)

The contacts of the temperature control switch are in the compressor motor's running and starting circuits. They are also in the condenser fan motor circuit.

When the cabinet temperature gets up to the cut-on setting, the temperature control switch closes in the compressor motor's starting and running circuits and in the condenser fan circuit. When the cabinet temperature gets down to the cut-off setting, the temperature control switch opens in these circuits.

CAUTION: To adjust temperature control see pages 51 and 52 "Things To Adjust."

STARTING RELAY

The starting relay (in the terminal box on the side of the compressor shell) is an electromagnetic relay whose contacts are closed by the magnetic field of the relay coil, and are opened by gravity. It is made up of a relay coil and one set of contacts. The relay coil is in the running circuit of the compressor motor. The relay contacts are in the compressor motor's starting circuit and can complete or break only that circuit.

When the compressor motor and the condenser fan motor first start, the starting relay closes and completes the compressor motor starting, winding circuit. After the compressor motor gets up speed, the starting relay is opened by the force of gravity and the starting winding circuit is broken.

COMPRESSOR MOTOR

The compressor motor (sealed in the compressor housing) runs the compressor. It is started by the temperature control switch, the starting relay and the thermal overload switch. It is stopped by the temperature control switch, and, if it gets overloaded, by the thermal overload switch.

HOW THE REFRIGERATION SYSTEM WORKS (Cont.)**– ELECTRICAL PARTS – (Cont.)****THERMAL OVERLOAD ASSEMBLY**

The thermal overload assembly (in the terminal box on the side of the compressor shell) is the name of a part that is made up of a switch (the thermal overload switch) and a heating wire. The heating wire is in the compressor motor's running and starting circuits. The thermal overload switch can complete or break the compressor motor's starting circuit and running circuit. If the compressor motor gets too warm, or draws too much current (which will make the heating wire get hot) the heat makes the thermal overload switch open in the running and starting circuit of the compressor and break those circuits. When the thermal overload assembly, the motor, and the compressor shell have all cooled enough to run safely, the thermal overload switch closes in these circuits and completes them.

CONDENSER FAN MOTOR

The condenser fan motor (between the condenser and the motor compressor) runs a fan that sucks air through the condenser coils. It starts when the temperature control switch is closed and it stops when the temperature control switch is open.

HOW THE REFRIGERATION SYSTEM WORKS (Cont.)

– ELECTRICAL OPERATION –

WHAT DOES IT	WHAT HAPPENS
WHEN THE VENDER TEMPERATURE GETS UP TO THE CUT-ON SETTING	
<p>The temperature control switch</p>	<p>Closes in the running winding circuit of the compressor motor and completes that circuit.</p> <p>Closes in the starting relay coil circuit, and completes that circuit.</p> <p>Closes in the starting winding circuit of the compressor motor.</p> <p>Closes in the condenser fan motor circuit, completing the circuit.</p>
THE HEAVY CURRENT, DRAWN BY THE RUNNING WINDING, ALSO FLOWS IN THE STARTING RELAY COIL, AND:	
<p>The starting relay coil</p>	<p>Closes the starting relay contacts in the starting winding circuit of the compressor motor, completing that circuit.</p>
WHEN THE COMPRESSOR MOTOR GETS UP TO SPEED	
<p>The force of gravity</p>	<p>Pulls the starting relay contacts apart because</p>
<p>The starting relay coil</p>	<p>No longer gets enough current to hold the contacts closed, and</p>
<p>The starting relay contacts</p>	<p>Open in the starting winding circuit of the compressor motor, and break that circuit.</p>
IF EITHER THE COMPRESSOR MOTOR OR THE CONDENSER FAN DRAWS TOO MUCH CURRENT AND CAUSES THE THERMAL OVERLOAD ASSEMBLY TO GET TOO WARM	
<p>The thermal overload switch</p>	<p>Opens in the running winding circuit and the starting winding circuit of the compressor motor, and breaks both those circuits.</p> <p>Opens in the condenser fan motor circuit, and breaks that circuit.</p>

HOW THE REFRIGERATION SYSTEM WORKS (Cont.)

– ELECTRICAL OPERATION – (Cont.)

WHAT DOES IT	WHAT HAPPENS
WHEN THE THERMAL OVERLOAD ASSEMBLY COOLS DOWN AGAIN	
The thermal overload switch	<p>Closes in both the running winding circuit and the starting winding circuit of the compressor motor.</p> <p>Closes in the condenser fan motor circuit, and completes that circuit</p>
WHEN THE VENDER TEMPERATURE GETS DOWN TO THE CUT-OFF SETTING	
The temperature control switch	<p>Opens in the running winding circuit of the compressor motor, and breaks that circuit.</p> <p>Opens in the starting relay coil circuit, and breaks that circuit.</p> <p>Opens in the starting winding circuit of the compressor motor.</p>

HOW THE REFRIGERATION SYSTEM WORKS (Cont.)

– ELECTRIC CIRCUITS AND CIRCUIT DIAGRAMS –

CONDENSER FAN CIRCUIT

SWITCHES IN THE WIRING	WHAT THE SWITCHES DO	WHAT MAKES THE SWITCHES WORK
Temperature control switch	Turns the condenser fan motor on and off.	The temperature in the vender has come up to the cut-on point (or gotten down to the cut-off point) set on the temperature control.

COMPRESSOR MOTOR RUNNING WINDING CIRCUIT

SWITCHES IN THE WIRING	WHAT THE SWITCHES DO	WHAT MAKES THE SWITCHES WORK
Thermal overload switch	Turns the running windings of the compressor motor on.	Current drawn by the motor or heat from the compressor can raise the temperature of the thermal overload assembly and make the thermal overload switch cut off.

HOW THE REFRIGERATION SYSTEM WORKS (Cont.)

- ELECTRIC CIRCUITS AND CIRCUIT DIAGRAMS - (Cont.)

CONDENSER FAN CIRCUIT DIAGRAM

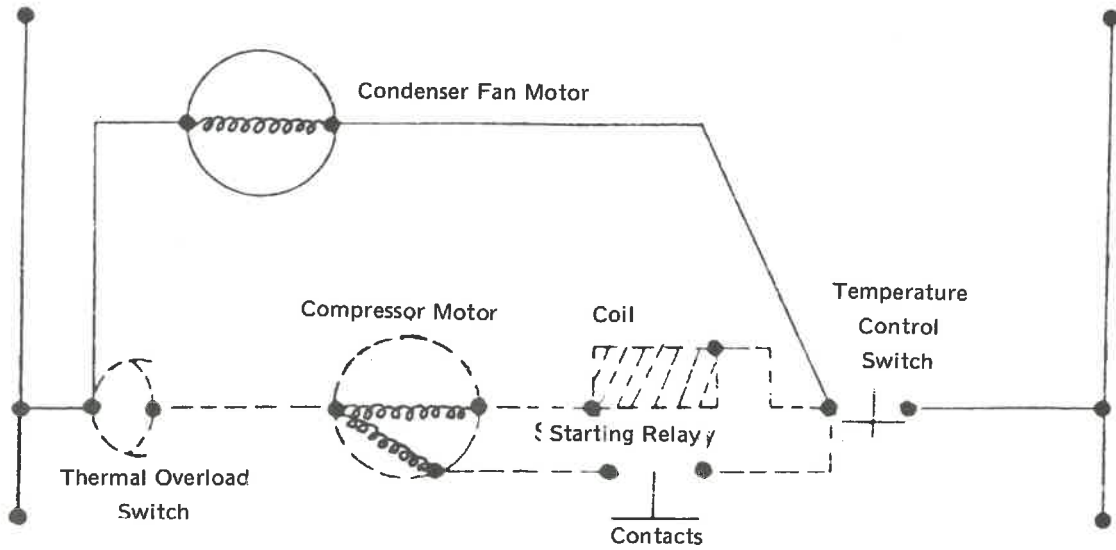

COMPRESSOR MOTOR RUNNING WINDING CIRCUIT DIAGRAM

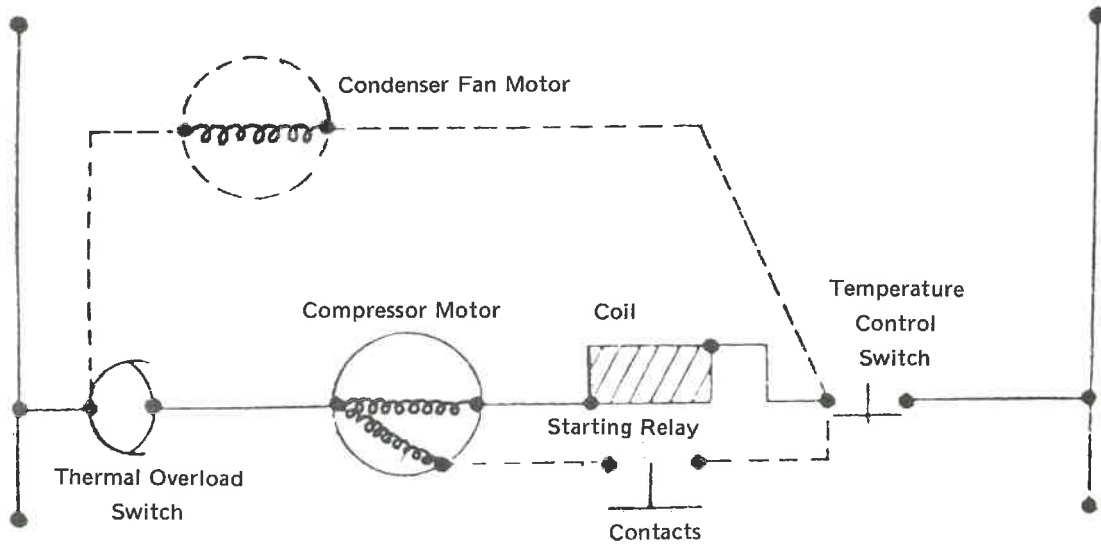

HOW THE REFRIGERATION SYSTEM WORKS (Cont.)
– ELECTRIC CIRCUITS AND CIRCUIT DIAGRAMS – (Cont.)

COMPRESSOR MOTOR STARTING WINDING CIRCUIT

SWITCHES IN THE WIRING	WHAT THE SWITCHES DO	WHAT MAKES THE SWITCHES WORK
Temperature control switch	Turns the starting windings of the compressor motor on.	The temperature in the vender has come up to the cut on point set on the temperature control.
Starting relay contacts	Turns the starting windings of the compressor motor on and off.	The current drawn by the running winding of the com- pressor motor when it is first turned on also closes through the starting coil. This heavy current gives the relay coil enough power to close the contacts.
Thermal overload switch	Turns the starting windings of the compressor motor on and off.	Current drawn by the motor or heat from the com- pressor can raise the temperature of the thermal over- load assembly and make the thermal overload switch open.

HOW THE REFRIGERATION SYSTEM WORKS (Cont.)
- ELECTRIC CIRCUITS AND CIRCUIT DIAGRAMS - (Cont.)

COMPRESSOR MOTOR STARTING WINDING CIRCUIT DIAGRAM

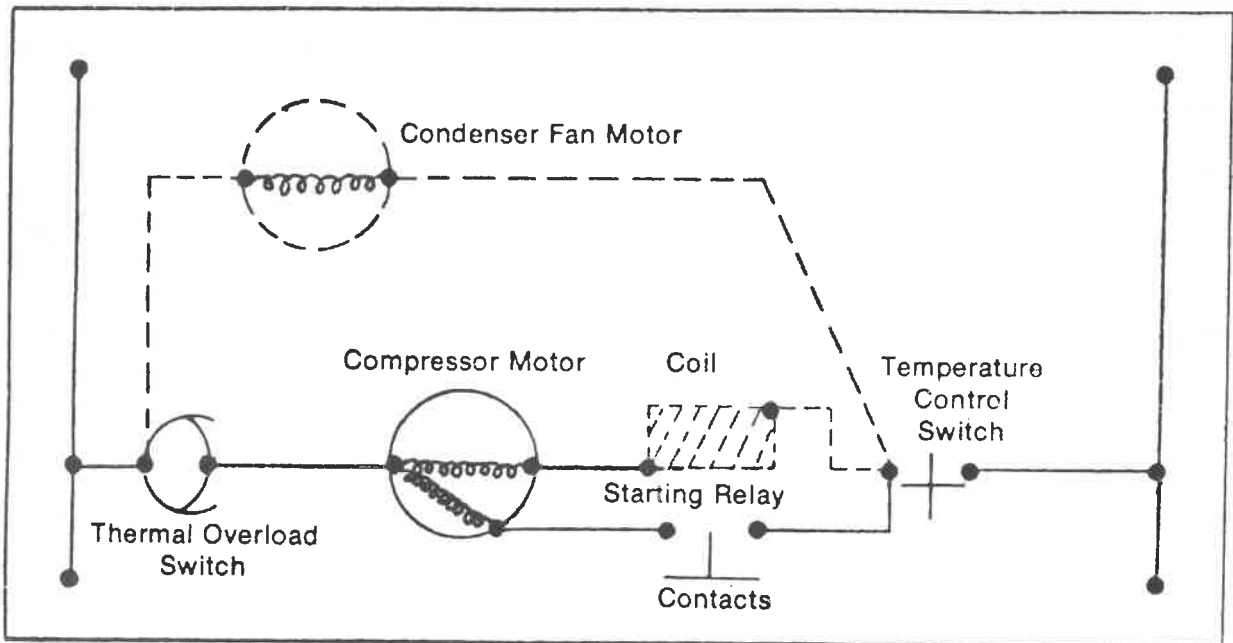

HOW THE REFRIGERATION SYSTEM WORKS (Cont.)

– REFRIGERATION CYCLE –

<u>What Does It</u>	<u>What Happens</u>
The rising temperature in the vender	Warms the temperature control bulb and the liquid in it.
The liquid in the control bulb.	Expands and pushes through the control tube and stretches the temperature control bellows.
The bellows	Moves, and closes the temperature control switch.
The temperature control switch	Turns the compressor motor on. Turns the condenser fan motor on.
The compressor motor	Drives the compressor.
The condenser fan motor	Drives the condenser fan.
The condenser fan motor	Sucks air through the condenser, cooling it.
The compressor	Sucks low pressure refrigerant gas from the evaporator, compresses the gas, and pumps it to the condenser.
The cooled condenser	Takes the heat out of the high pressure refrigerant gas.
The cooled gas	Turns into liquid refrigerant.
More hot gas coming from the compressor	Pushes the liquid refrigerant into the capillary tube.
The capillary tube	Lets only a certain amount of liquid refrigerant run into the evaporator.
The evaporator	(Where the pressure is kept low by the suction of the compressor) heats the liquid refrigerant.
The liquid refrigerant	Changes into gas at low pressure and is sucked below into the compressor.
The falling temperature in the vender	Cools the temperature control bulb and the liquid in it.

HOW THE REFRIGERATION SYSTEM WORKS (Cont.)**– REFRIGERATION CYCLE – (Cont.)**

<u>What Does It</u>	<u>What Happens</u>
The liquid in the control bulb	Shrinks, and lets the temperature control bellows pull back
The bellows	Move, and open the temperature control switch.
The temperature control switch	Turns the compressor motor off. Turns the condenser fan motor on.
The compressor	Stops.
The condenser fan motor.	Stops.

(With the vender "Plugged In" the evaporator fan motor runs constantly)

**HOW TO TAKE CARE OF
THE REFRIGERATION SYSTEM**

– WHAT TO CLEAN –

Clean dirt and lint from the condenser with a brush, vacuum cleaner or compressed air

– WHEN AND WHAT TO LUBRICATE –

The refrigeration system is sealed up and does not have to be oiled or greased. Enough oil is put into the condenser and evaporator fan motors when they are manufactured to last as long as they will run.

– CORRECTING TROUBLES –

When the refrigeration system is not working right, go to the table called "Correcting Common Refrigeration Troubles" on the next pages. Find your trouble, see what the possible causes are, and try the tests (in the center column): they will let you know when you have the true cause of the trouble. When you have found the cause of the trouble, either make the adjustment, repair the part or put a new part in, whatever the table says to do. This table does not list all of the possible causes of any of the troubles — but it does have all of the common causes. If your vender has a trouble that is not shown on the chart, or the trouble is not the result of one of the causes shown on the chart, study the section on "How The Refrigeration Mechanism Works" and you will be able to find out what is wrong and fix it.

**HOW TO CORRECT
COMMON REFRIGERATION TROUBLES**

TROUBLE

THE COMPRESSOR WILL NOT RUN AT ALL	42
THE COMPRESSOR STARTS BUT WILL NOT KEEP RUNNING	44
THE COMPRESSOR RUNS BUT THE CANS/BOTTLES AREN'T COLD ENOUGH	46
THE CANS/BOTTLES ARE TOO COLD	49
THE REFRIGERATION UNIT IS NOISY	49
THE COMPRESSOR MOTOR NEVER STOPS RUNNING	50

**HOW TO CORRECT
COMMON REFRIGERATION TROUBLES (Cont.)**

THE COMPRESSOR RUNS BUT THE CANS/BOTTLES AREN'T COLD ENOUGH

A POSSIBLE CAUSE IS	TO MAKE SURE	THIS IS WHAT TO DO
1. The evaporator fan is not working.	Look. If it is not working.	Check the "Possible Causes" in the next step. If it is working, skip the next step and go on to step 3 of this section.
2. The evaporator fan motor is burned out.	Remove black rubber junction block located on the fan motor bracket. Connect a 110V line to the evaporator fan motor leads. If the evaporator fan motor doesn't start,	Put a new evaporator fan motor in.
3. The temperature control cam is set too warm (high).	Turn the outside range screw of the temperature control clockwise to a colder setting and let the vender run overnight. If the cans/bottles get cold enough,	Leave the temperature control at that setting.
4. The evaporator is covered with frost and ice.	If the cans/bottles did not get colder, Look at it.	Put a new temperature control in.
5. The temperature control cam is set too cold and the evaporator is not defrosting.	Look at the evaporator for frost. If there is frost,	Defrost the evaporator then check the "Possible Causes" in the next 2 steps. If it isn't skip the next 2 steps and go to step 8 of this section.
	If the evaporator coil does not defrost on each cycle.	Turn the inside range screw.
	If, after the second setting, the coil still does not defrost,	Turn the inside range screw.
		Put a new temperature control in.

**HOW TO CORRECT
COMMON REFRIGERATION TROUBLES (Cont.)**

THE COMPRESSOR RUNS BUT THE CANS/BOTTLES AREN'T COLD ENOUGH (Cont.)

A POSSIBLE CAUSE IS	TO MAKE SURE	THIS IS WHAT TO DO
6. The temperature control switch contacts stick closed.	If the unit runs all the time, and the evaporator builds up frost.	Put a new temperature control in.
7. The temperature control bulb sleeve is touching the evaporator.	Look at it. If it is touching the evaporator tube.	Bend the bracket so that there will be space between the bulb sleeve and the evaporator tube.
8. The control bulb is not in the sleeve (holder).	Look. If it is not.	Put the bulb in the sleeve (holder).
9. The temperature control bellows is not working.	Warm the temperature control bulb with your hand for about one minute. If the temperature control switch doesn't close,	Put a new temperature control in.
10. The refrigerant tubing is kinked or bent sharply.	Look, if it is,	Try to get the kink out.
11. There isn't enough refrigerant in the refrigeration system or the capillary tube is partly plugged.	If this does not help and no other cause can be found for the trouble.	Put some new refrigerant tubing in.
12. The condenser isn't getting enough air.	Let the vender run at least 15 minutes and then see if the evaporator is frosted all over. If it isn't,	Try to blow the plug out of the capillary tube, evacuate the system and then put a new charge of gas in the refrigeration unit.
13. The condenser is dirty.	See if there is anything around the outside of the vender to keep the air out. If there is,	Take it away.
	Look. Also feel the tube from the compressor to the condenser. If the tube is very hot, or if you see dirt,	Clean the condenser with either a vacuum cleaner, a brush or compressed air.

**HOW TO CORRECT
COMMON REFRIGERATION TROUBLES (Cont.)**

THE COMPRESSOR RUNS BUT THE CANS/BOTTLES AREN'T COLD ENOUGH (Cont.)

A POSSIBLE CAUSE IS	TO MAKE SURE	THIS IS WHAT TO DO
<p>14. The condenser fan motor is burned out.</p>	<p>With the condenser fan motor leads correctly connected to the compressor terminal, see if the condenser fan runs when the compressor does. If it doesn't,</p>	<p>Put a new condenser fan motor in.</p>
<p>15. The thermal overload switch is starting and stopping the compressor.</p>	<p>Unplug the vender for at least 15 minutes, then plug it in again. Be sure the temperature control switch is closed. (Warm the temperature control bulb with your hand to close it.) If the compressor motor cuts off then on, then off while the temperature control switch stays closed.</p>	<p>Check the "Possible Causes" in steps 16 and 17.</p>
<p>16. The voltage at the vender is either too high or too low.</p>	<p>1. When an extension is not used on the supply cord: While the compressor is running put one prod of a volt meter on terminal (S) of the starting relay and the other prod on terminal (L) of the starting relay. If the voltage is not between 105V and 126V,</p> <p>2. When an extension is used on the supply cord: Put a double socket on the plug end of the extension and plug it into the outlet. While the compressor is running, put the prods of a volt meter on terminal (S) of the starting relay and the other prod on terminal (L) of the starting relay. If the voltage is not between 105V and 126V.</p>	<p>Have the person in charge of the vender tell the power company so they can take care of it</p> <p>Have the person in charge of the vender tell the power company so they can take care of it.</p>

**HOW TO CORRECT
COMMON REFRIGERATION TROUBLES (Cont.)**

THE COMPRESSOR RUNS BUT THE CANS/BOTTLES AREN'T COLD ENOUGH (Cont.)

A POSSIBLE CAUSE IS	TO MAKE SURE	THIS IS WHAT TO DO
<p>17. The starting relay contacts are sticking closed.</p>	<p>Look and see. If they are,</p>	<p>Put a new starting relay in.</p>
THE CANS/BOTTLES ARE TOO COLD		
<p>1. The temperature control bulb is not in its tube.</p>	<p>Look and see. If it isn't,</p>	<p>Put the bulb in its tube.</p>
<p>2. The temperature control cam is set too cold.</p>	<p>Turn the outside range screw of the temperature control cam counter-clockwise to a warmer setting and let the vender run over night. If the cans/bottles get cold enough but not too cold, unplug the vender and let the evaporator fan come to a stop</p>	<p>Leave the temperature control cam at that setting</p>
<p>3. The temperature control switch is stuck closed.</p>	<p>Then block the fan blade so it can't turn. Remove the temperature control bulb from its tube and touch it to the evaporator tube. Plug the vender back in and let the compressor run until it cuts off, but not more than 30 minutes. If the vender has not cut off.</p>	
THE REFRIGERATION UNIT IS NOISY		
<p>1. The refrigerant lines rattle.</p>	<p>Hold them between your fingers. If the rattle stops.</p>	<p>Bend them gently away from whatever they are hitting.</p>

**HOW TO CORRECT
COMMON REFRIGERATION TROUBLES (Cont.)
THE COMPRESSOR MOTOR NEVER STOPS RUNNING**

A POSSIBLE CAUSE IS	TO MAKE SURE	THIS IS WHAT TO DO
<p>1. The temperature control switch is stuck closed.</p> <p>2. The compressor has a broken valve or no refrigerant in the refrigeration system.</p>	<p>Turn the inside range screw cam and the range screw to their warmest settings. Let the venter run overnight, or until it stops, If the compressor motor doesn't stop running.</p> <p>The tube from the compressor to the condenser is not warm and the evaporator is not cold,</p> <p>If this does not help,</p>	<p>Put a new temperature control in.</p> <p>Put a new charge of refrigeration in the refrigeration unit.</p> <p>Put a new motor compressor in the refrigeration unit.</p>

**HOW TO CORRECT
COMMON REFRIGERATION TROUBLES (Cont.)**

- WIRING DIAGRAM -

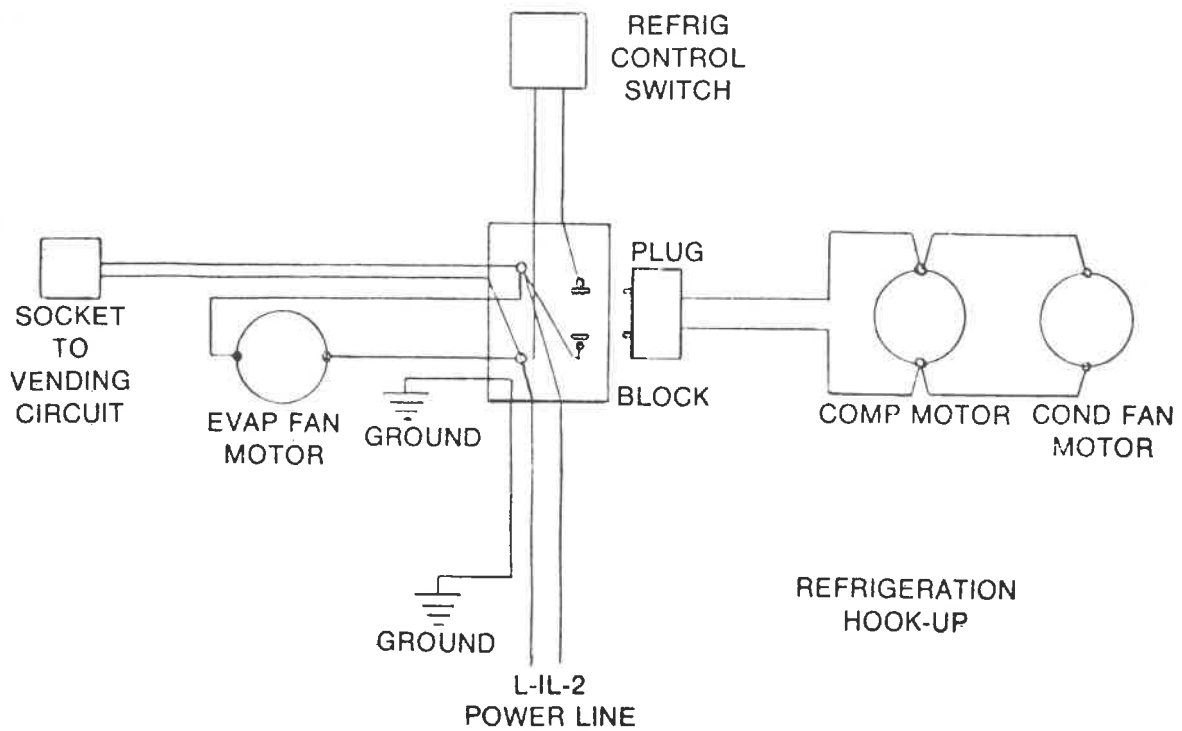
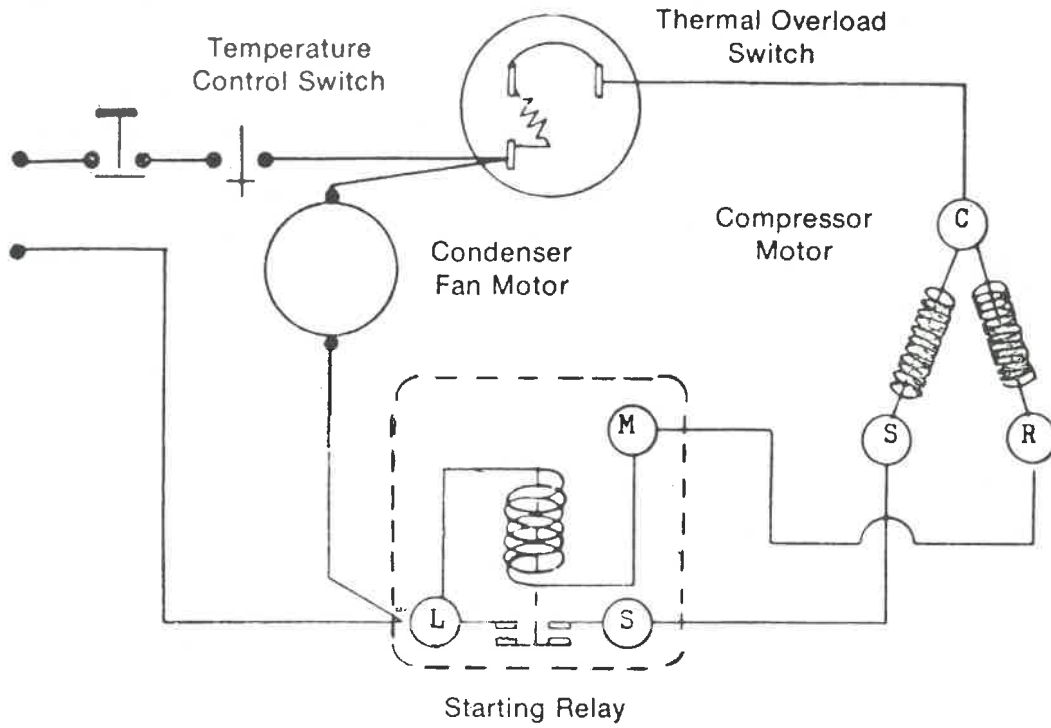

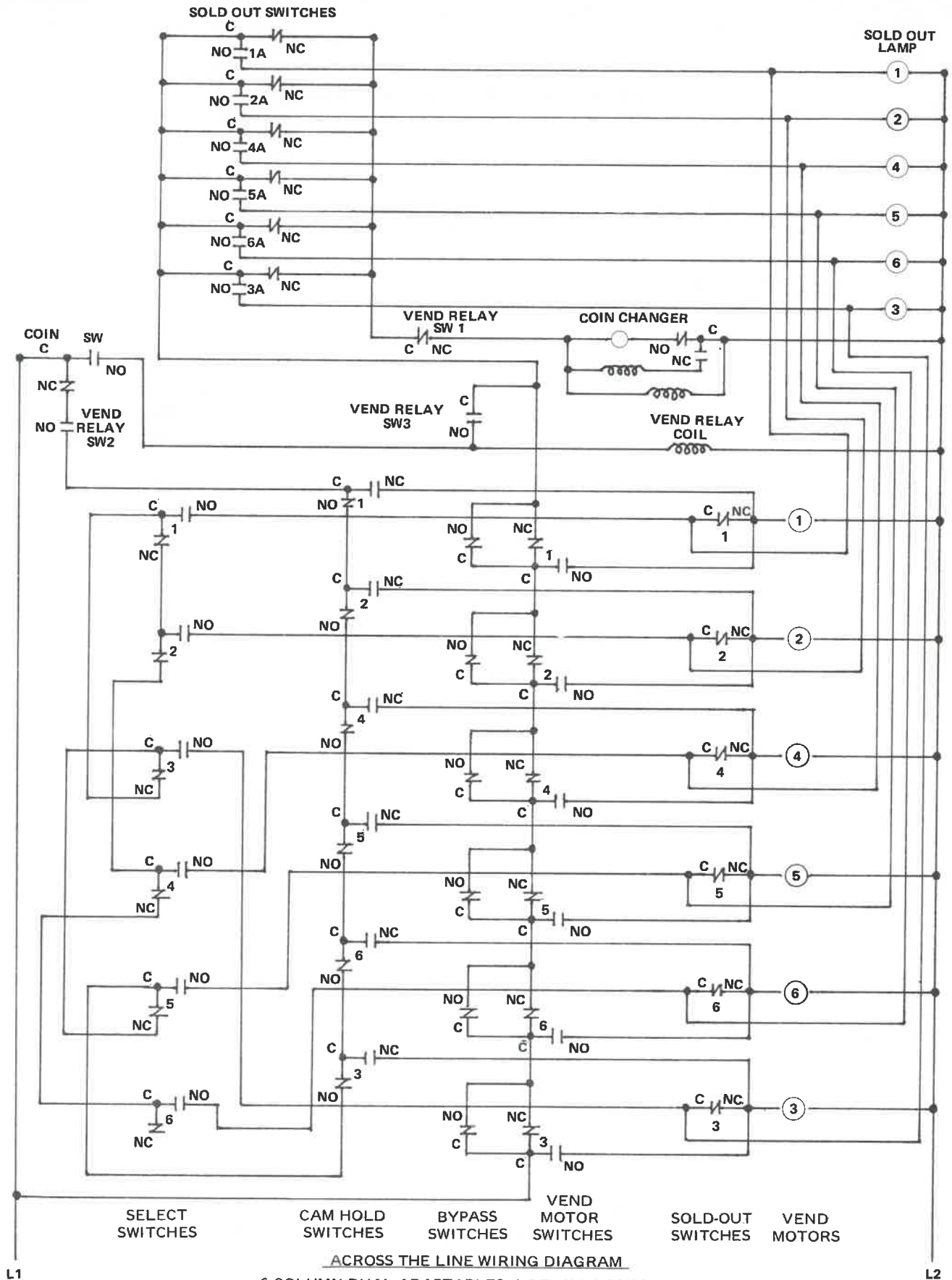

ACROSS THE LINE WIRING DIAGRAM

6 COLUMN DUAL ADAPTIBLES, 1 RELAY, LOCKOUT
 ALL SWITCHES SHOWN IN POSITION WHEN VENDOR IS READY
 TO ACCEPT COINS

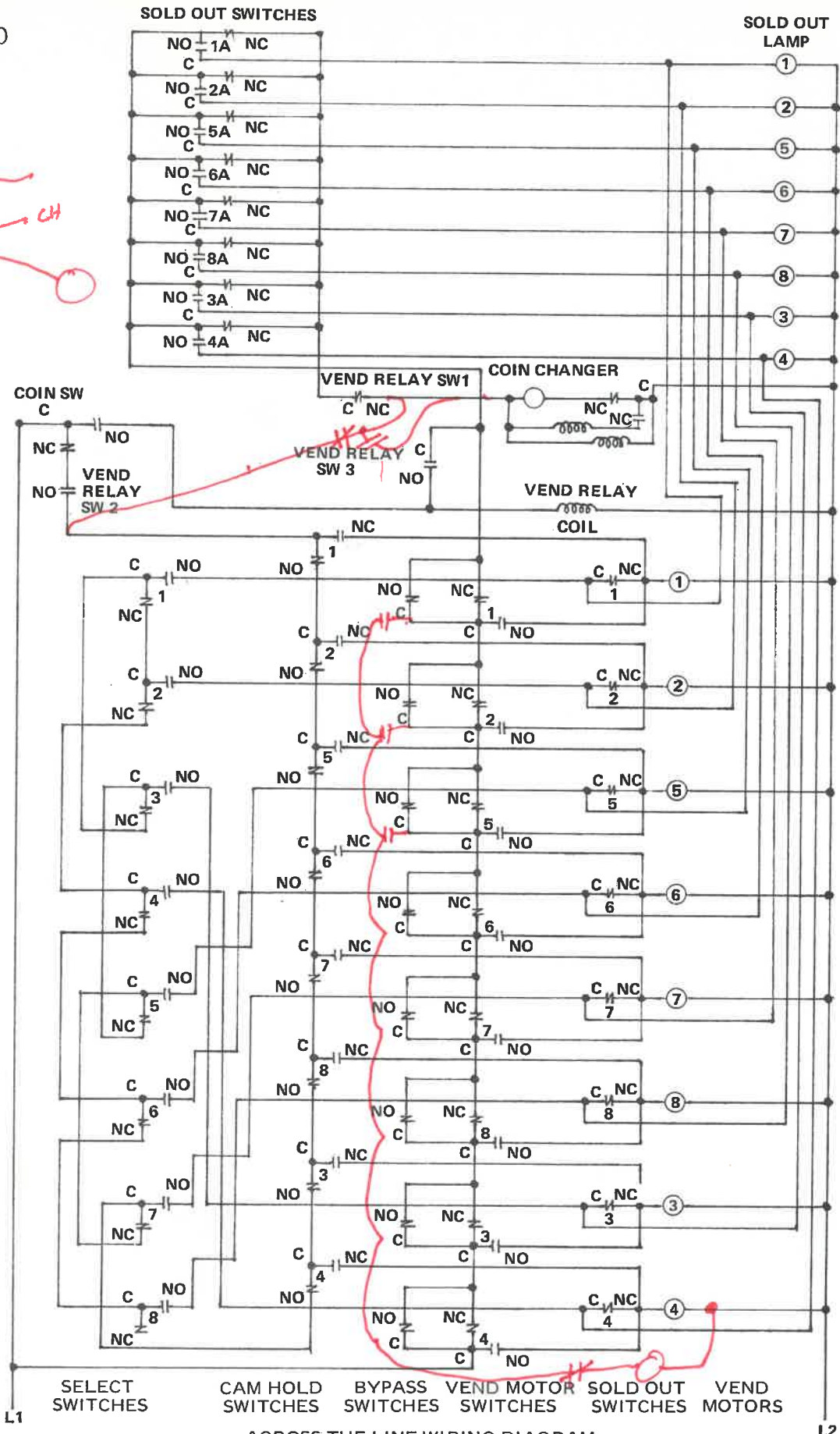
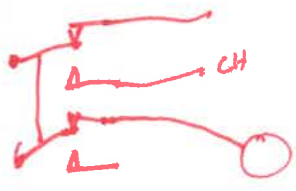

ACROSS THE LINE WIRING DIAGRAM

8 COLUMN ADAPTABLES, 1 RELAY, LOCKOUT
 ALL SWITCHES SHOWN IN POSITION WHEN VENDER IS READY TO ACCEPT COINS

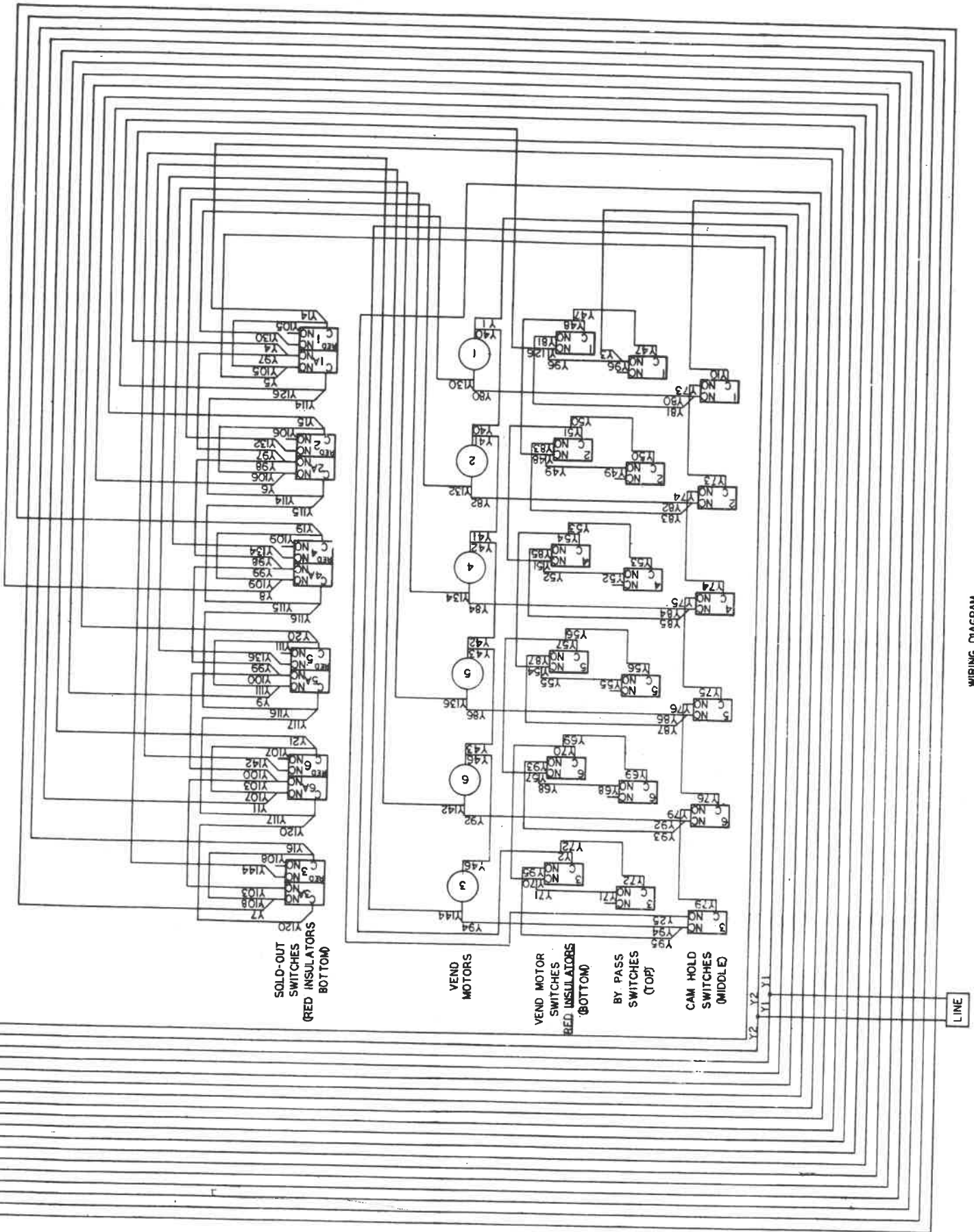

WIRING DIAGRAM
6 COLUMN DUAL ADAPTABLES

54A

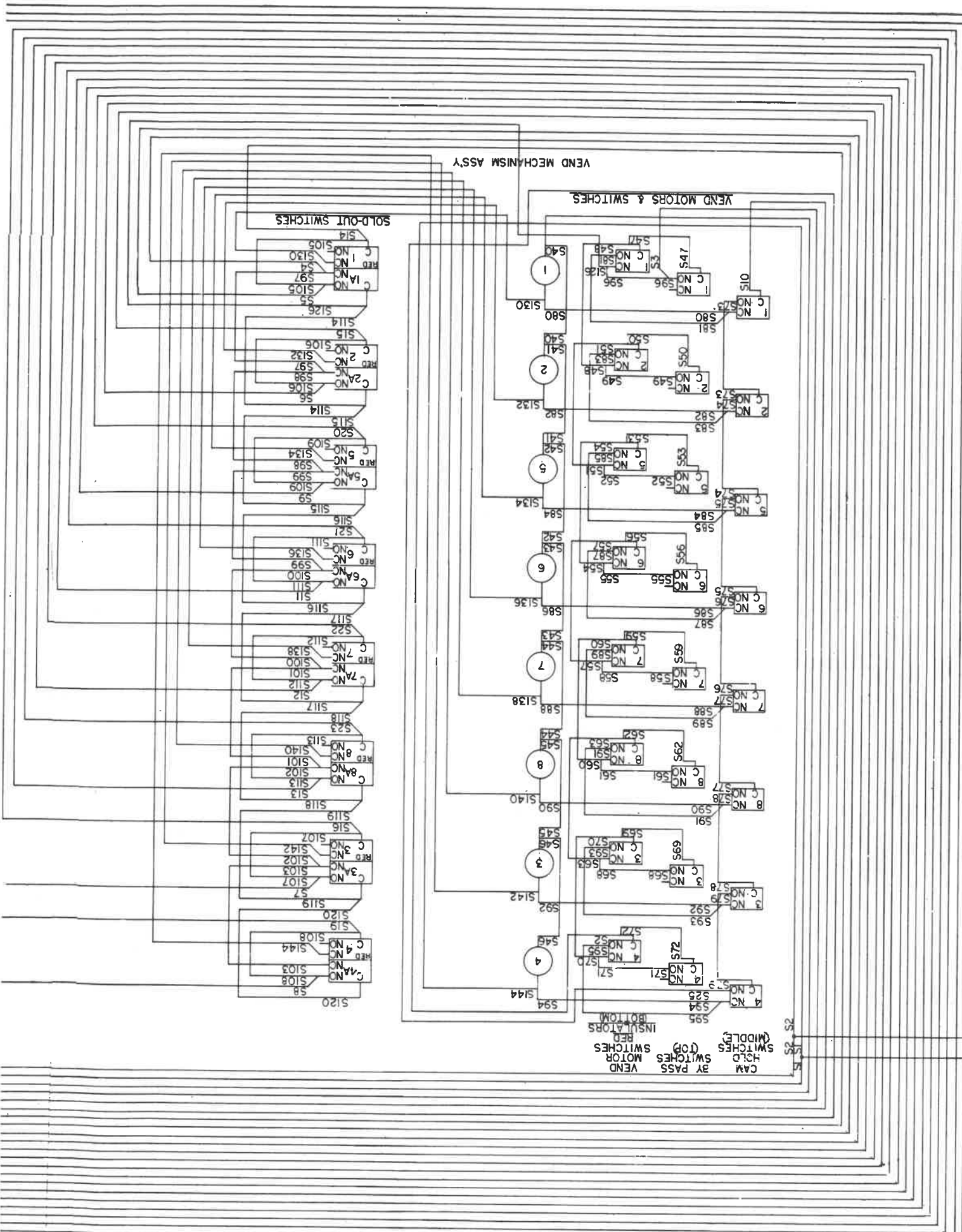

VEND MECHANISM ASSY

VEND MOTORS & SWITCHES

SOLD-OUT SWITCHES

F 80 3812110.01

WIRING DIAGRAM
8 PRODUCT ADAPTABLES

LINE

6/1/58 R.W.P.

WIRING DIAGRAM

55A

DIXIE-
NARCO

PATENT NOTICE
THIS DEVICE IS MANUFACTURED UNDER ONE OR MORE OF THE FOLLOWING U.S. PATENTS:
3,115,274 3,463,355 4,019,650
3,144,965 3,464,589 4,036,400
3,187,941 3,680,987 4,036,621
3,702,164 4,044,877

NOTE:
SOME MODELS
HAVE ILLUMINATED
SIGN ASSYS

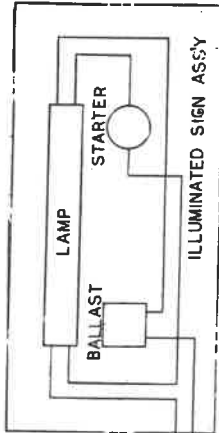

ON ALL CAPS & PLUGS
PIN 1 IS LOCATED ADJACENT
TO CORNER HAVING RIB.
EXAMPLES:

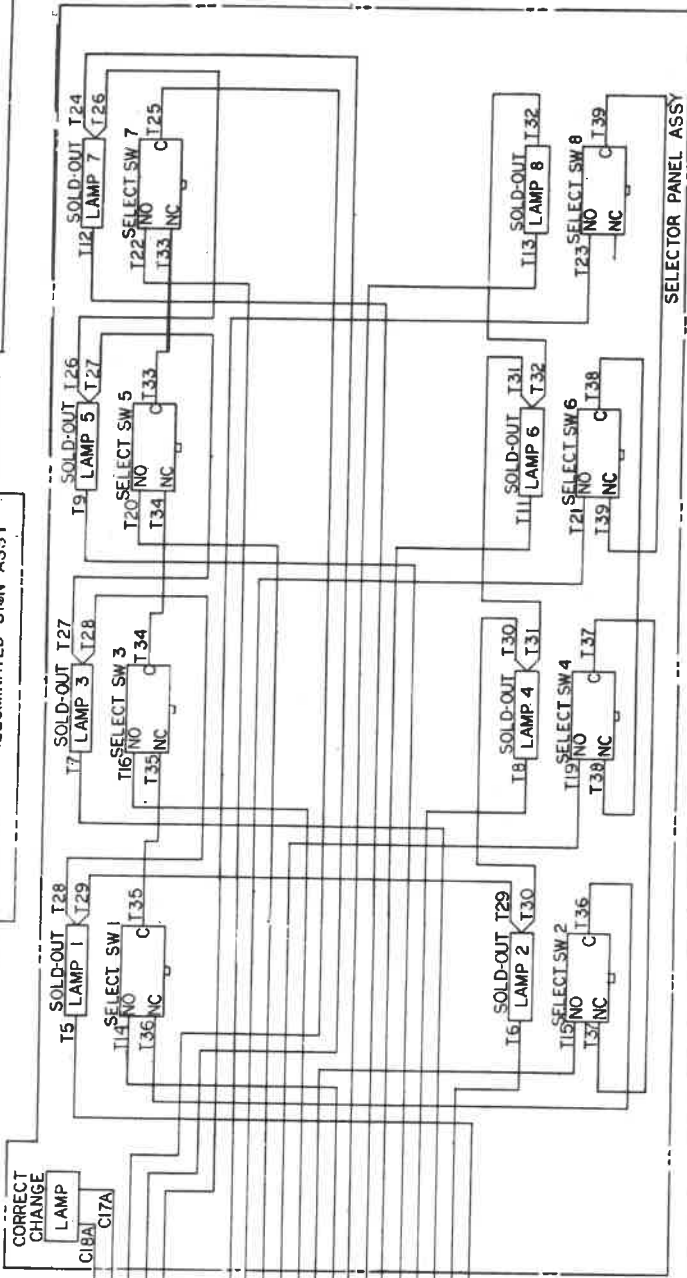
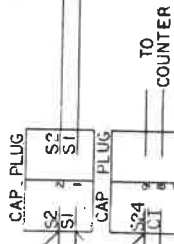

SELECTOR PANEL ASSY

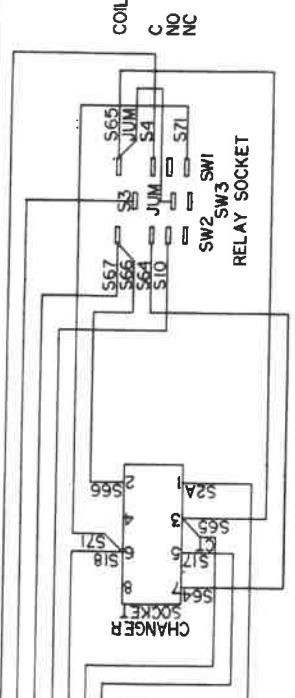

MAIN DOOR

ITEM NO.	PART NUMBER	PART NAME AND DESCRIPTION
		DCB156/93-6
1	<u>MUST SPECIFY MODEL & SERIAL NO.</u>	Main Door Assembly
2	D207,050,300.43C	Main Door, W/A
3	805,001,830.01	Illuminated Sign
4	B207,050,020.13	Sign Retainer, sides
5	A208,050,240.23	Sign Frame, side
		DCB228/132-6
1	<u>MUST SPECIFY MODEL & SERIAL NO.</u>	Main Door Assembly
2	D214,050,300,43B	Main Door, W/A
3	805,001,830.01	Illuminated Sign
4	B207,050,020.13	Sign Retainer, Sides
5	A208,050,240.23	Sign Frame, Sides
		DCB264/156-6
1	<u>MUST SPECIFY MODEL & SERIAL NO.</u>	Main Door Assembly
2	D214,050,300.43D	Main Door, W/A
3	805,002,130.01	Illuminated Sign
4	A215,050,060.03	Sign Retainer, Sides
5	A216,050,030.03	Sign Frame, Sides
		DCB318/183-6
1	<u>MUST SPECIFY MODEL & SERIAL NO.</u>	Main Door Assembly
2	D214,050,300.43A	Main Door, W/A
3	805,001,840.01	Illuminated Sign
4	B214,050,030.23	Sign Retainer, Sides
5	A214,050,020.13	Sign Frame, Sides
		DCB304/176-8
1	<u>MUST SPECIFY MODEL & SERIAL NO.</u>	Main Door Assembly
2	D211,050,300.63C	Main Door, W/A
3	805,001,850.01	Illuminated Sign
4	A209,050,010.25	Sign Retainer, Sides
5	A209,050,030.13	Sign Frame, Sides
		DCB352/208-8
1	<u>MUST SPECIFY MODEL & SERIAL NO.</u>	Main Door Assembly
2	D211,050,300.63B	Main Door, W/A
3	805,001,860.01	Illuminated Sign
4	B210,050,010.13	Sign Retainer, Sides
5	A210,050,020.13	Sign Frame, sides
		DCB424/244-8
1	<u>MUST SPECIFY MODEL & SERIAL NO.</u>	Main Door Assembly
2	D211,050,300.63A	Main Door, W/A
3	805,001,870.01	Illuminated Sign
4	B211,050,020.13	Sign Retainer, Sides
5	B211,050,030.03	Sign Frame, Sides

WHEN ORDERING PARTS, INDICATE MODEL # AND SERIAL # OF VENDER.
ALL PRICES ARE SUBJECT TO CHANGE WITHOUT NOTICE.

MAIN DOOR

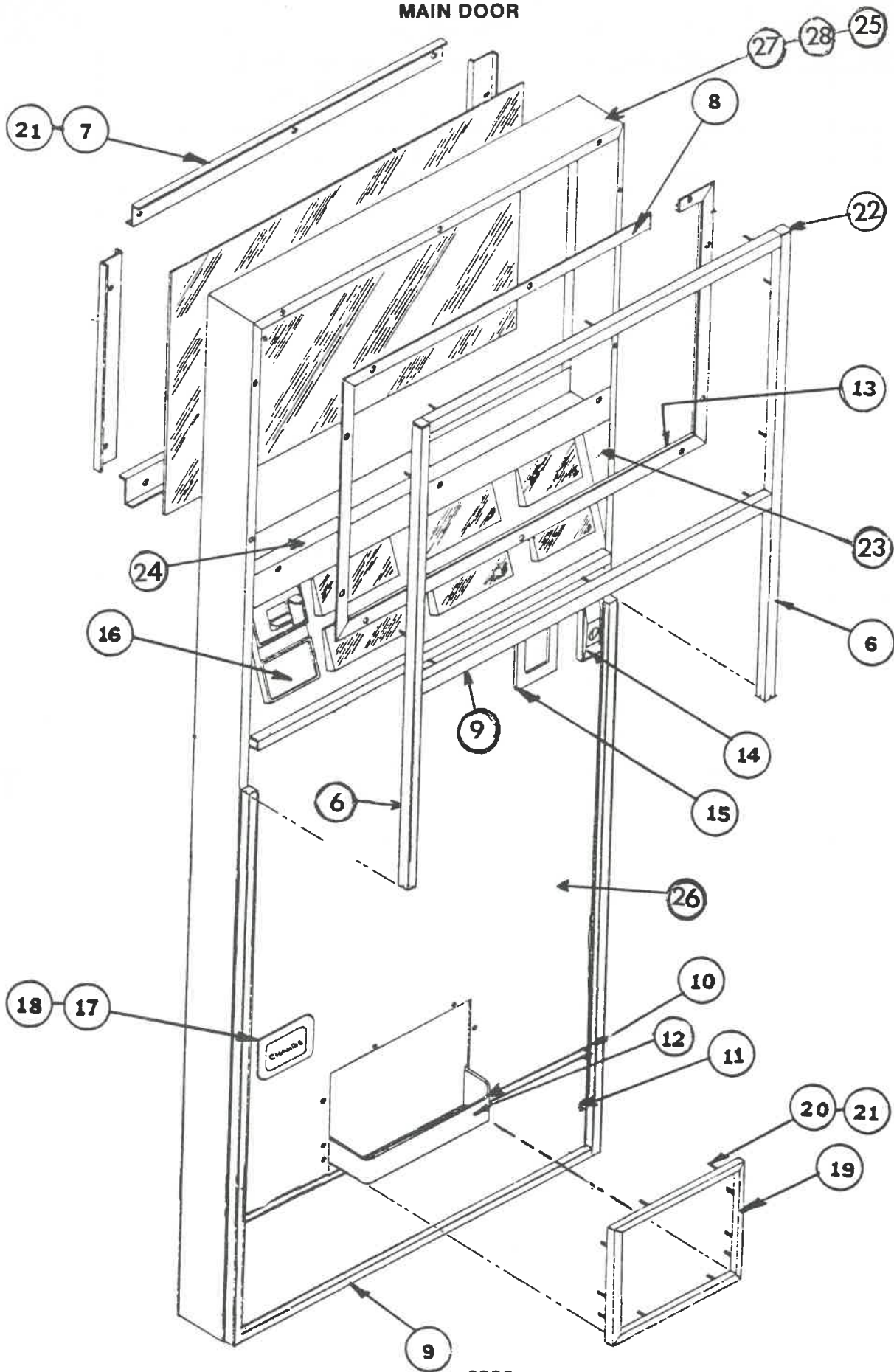

MAIN DOOR

ITEM NO.	PART NUMBER	PART NAME AND DESCRIPTION
6	801,602,700.01	DCB156/93-6 Vertical Trim
6	A801,602,740.01	DCB228/132-6 - DCB304/176-8 Vertical Trim
6	A801,602,750.01	DCB264/156-6 - DCB352/208-8 Vertical Trim
6	A801,602,730.01	DCB318/183-6 - DCB424/244-8 Vertical Trim
7	B207,050,010.23	DCB156/93-6 - DCB228/132-6 - DCB264/156-6 - DCB318/183-6 Sign Retainer, Top & Bottom
8	B208,050,250.13	Sign Frame, Top & Bottom
9	A801,602,690.01	Horizontal Trim
10	A801,602,520.01	Kickplate Divider Strip
11	C207,050,070.73	Kickplate
27	169,050,340.83	Rain Guard
7	B209,050,020.23	DCB304/176-8 - DCB352/208-8 - DCB424/244-8 Sign Retainer, Top & Bottom
8	B211,050,040.13	Sign Frame, Top & Bottom
9	A801,602,680.01	Horizontal Trim
10	A801,602,530.01	Kickplate Divider Strip
11	C211,050,070.83	Kickplate
28	B164,151,141.53	Ran Guard
12	B231,050,300.03	DCB156/93-6 - DCB228/132-6 - DCB264/156-6 - DCB318/183-6 - DCB304/176-8 DCB352/208-8 - DCB424/244-8 Discharge Member
13	903,600,410.01	Gasket (Specify Model)
14	A801,501,860.31	Pull Out Handle (Complete)
15	B801,303,500.41	Bezel, Bottle Opener
16	213,010,600.04	Coin Insert Assembly
17	B801,303,490.51	Bezel, Coin Return Cup
18	900,300,110.01	Screw, S/M #6 x 1/4
19	B801,602,660.01	Trim, Delivery Port
20	A900,400,350.31	Tee Bolt, #8-32 x 3/4
21	900,800,500.01	Keps Nut
22	801,803,940.01	Extrusion Cap
23	B169,050,071.03	End Channel
24	901,901,470.01	Clear Plastic
25	901,100,500.01	Pop Rivet
26	801,901,760.01	Blue Vinyl (Specify Model - Door)

WHEN ORDERING PARTS INDICATE MODEL # AND SERIAL # OF VENDER.
ALL PRICES ARE SUBJECT TO CHANGE WITHOUT NOTICE.

INTERIOR DOOR PARTS

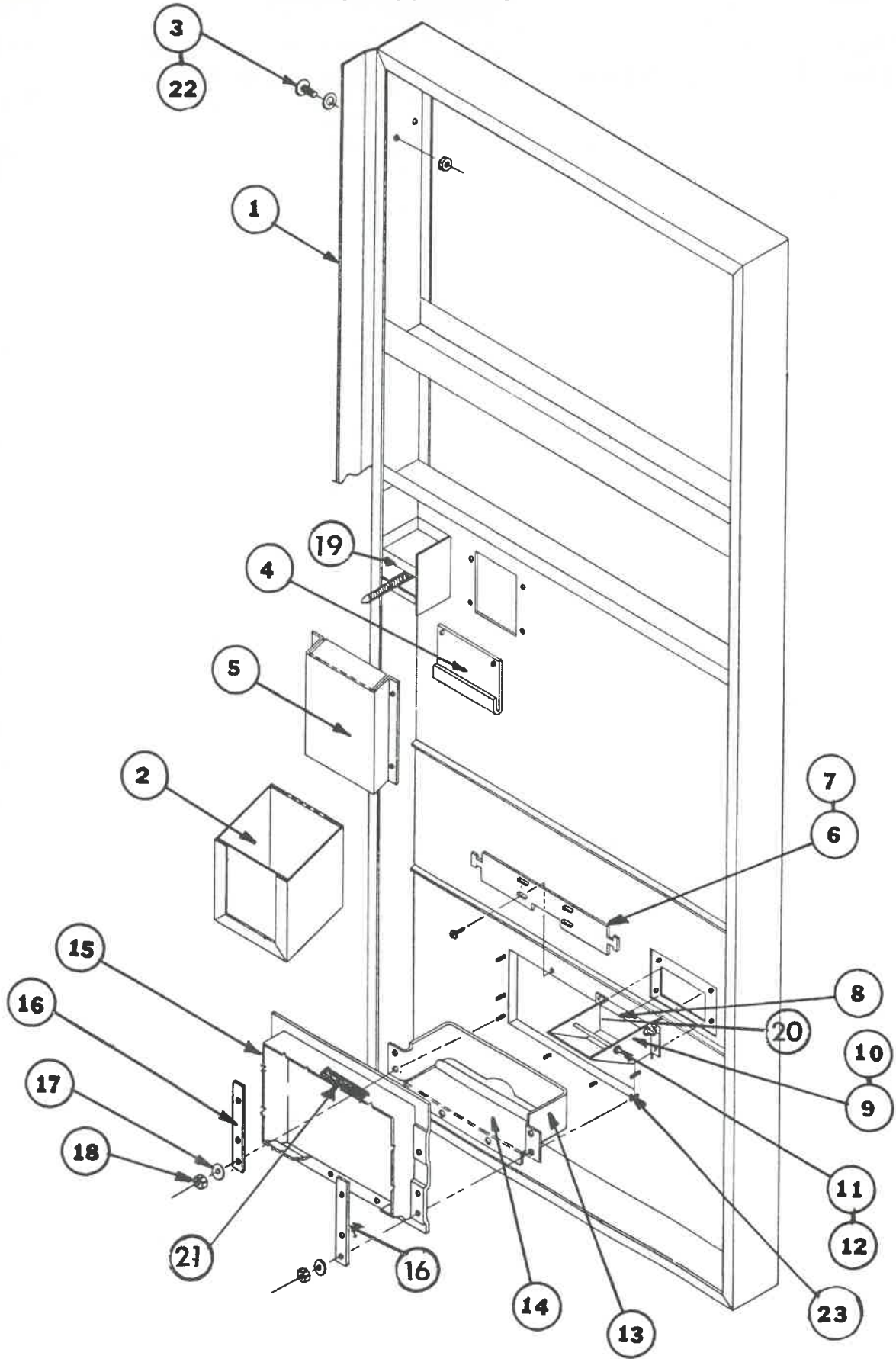

INTERIOR DOOR PARTS

ITEM NO.	PART NUMBER	PART NAME AND DESCRIPTION
1	C168,050,330.93	DCB156/93-6 Protective Plate, Door
1	C166,150,330.83	DCB228/132-6 - DCB304/176-8 Protective Plate, Door
1	C165,150,330.83	DCB264/156-6 - DCB352/208-8 Protective Plate, Door
1	C164,150,331.03	DCB318/183-6 - DCB424/244-8 Protective Plate, Door
DCB156/93-6 - DCB228/132-6 - DCB264/156-6 - DCB318/183-6 - DCB304/176-8 DCB352/208-8 - DCB424/244-8		
2	B211,051,400.03	Crown Catcher, S/A
3	900,201,200.01	Carriage Bolt and Nut
4	A211,050,230.23	Hanger, Crown Catcher
5	B73,052,161.23	Housing, Crown Puller
6	B172,050,031.33	Closure Strip
7	900,600,230.02	Screw, S/M #8 x 1/2
8	B801,803,930.11	Coin Return Door
9	B208,051,400.13	Coin Return Cup, S/A
10	900,300,110.01	Screw, S/M #6 x 1/4
11	A900,501,820.01	Hinge Pin
12	900,900,900.01	Retaining Ring
13	B231,050,300.03	Discharge Member
14	A172,050,300.73	Bumper Assembly
15	801,804,220.01	Delivery Chute
16	B169,050,370.93	Reinforcement Strip
17	900,700,060.01	Washer #8
18	900,800,500.01	Keps Nut 8-32
19	801,501,620.01	Latch Strike
20	A176,150,140.03	Closure Angle Coin Cup
21	A176,150,330.13	Port Retainer
22	900,700,710.01	Lockwasher, 1/4-20
23	A900,400,350.01	T-Bolt, 8-32 x 3/4

WHEN ORDERING PARTS INDICATE MODEL # AND SERIAL # OF VENDER.
ALL PRICES ARE SUBJECT TO CHANGE WITHOUT NOTICE.

INNER DOOR COMPLETE

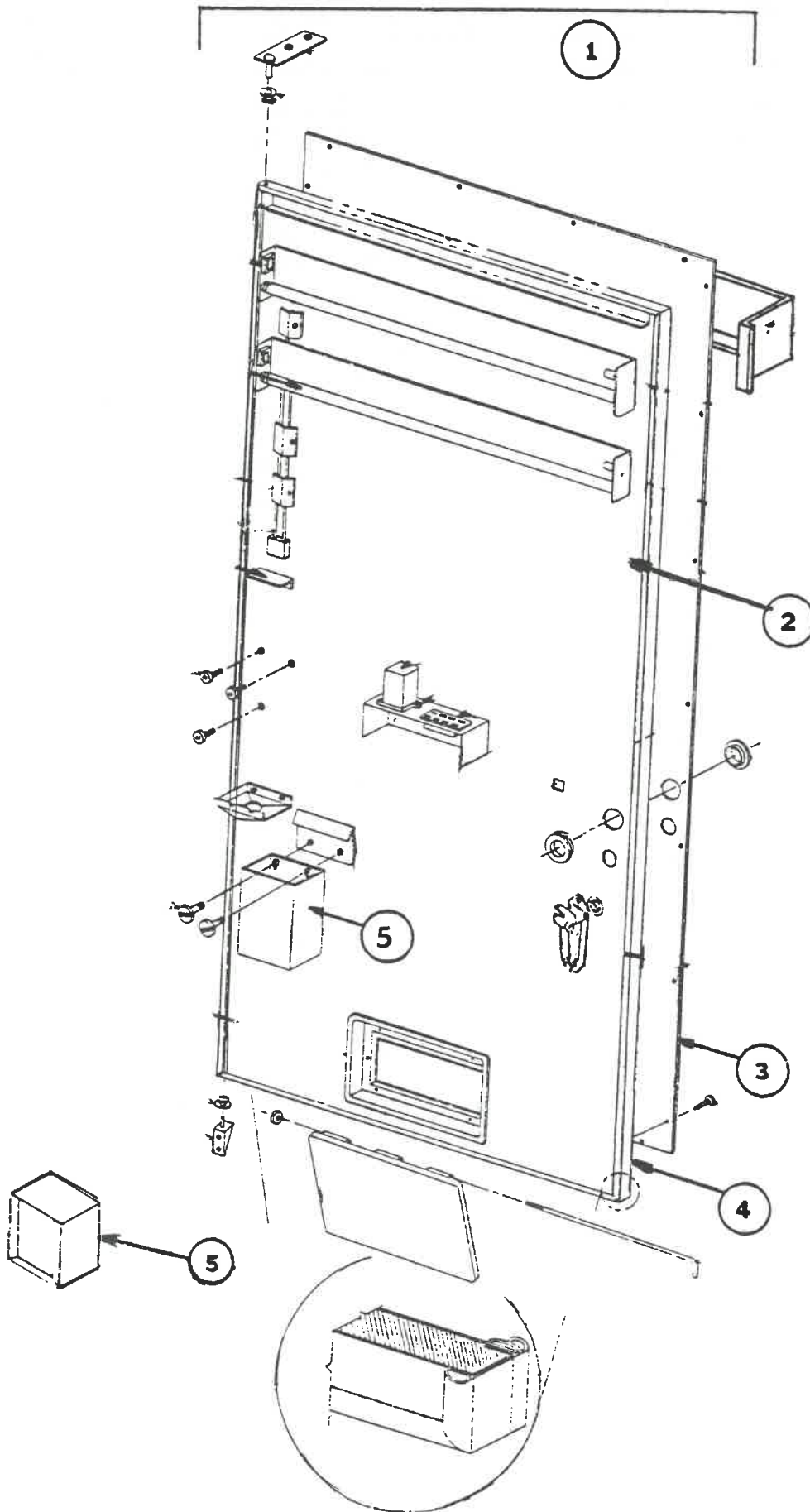

INNER DOOR

ITEM NO.	PART NUMBER	PART NAME AND DESCRIPTION
		DCB156/93-6
1	D214,050,100.83C	Inner Door Complete
2	D173,150,300.53	Foamed Assembly w/gasket
3	C173,150,020.73	Rear Panel
4	801,804,010.01	Gasket
5	B168,051,500.33	Cash Box, located in main door
		DCB228/132-6
1	D214,050,100.83B	Inner Door Complete
2	D172,150,300.53	Foamed Assembly w/gasket
3	C172,150,020.83	Rear Panel
4	801,804,020.01	Gasket
5	C172,150,600.13	Cash Box
		DCB264/156-6
1	D214,050,100.83D	Inner Door Complete
2	D215,050,400.43	Foamed Assembly w/gasket
3	C215,050,050.43	Rear Panel
4	801,804,030.01	Gasket
5	C172,150,600.13	Cash Box
		DCB318/183-6
1	D214,050,100.83A	Inner Door Complete
2	D213,050,300.73	Foamed Assembly w/gasket
3	D213,050,021.03	Rear Panel
4	801,804,040.01	Gasket
5	C172,150,600.13	Cash Box
		DCB304/176-8
1	D211,150,100.73C	Inner Door Complete
2	D178,150,300.53	Foamed Assembly w/gasket
3	C178,150,020.73	Rear Panel
4	801,804,050.01	Gasket
5	B176,151,100.13	Cash Box
		DCB352/208-8
1	D211,150,100.73B	Inner Door Complete
2	D177,151,300.53	Foamed Assembly w/gasket
3	C177,150,020.73	Rear Panel
4	801,804,060.01	Gasket
5	B176,151,100.13	Cash Box
		DCB424/244-8
1	D211,150,100.73A	Inner Door Complete
2	D176,150,300.53	Foamed Assembly w/gasket
3	C176,150,020.63	Rear Panel
4	801,804,070.01	Gasket
5	B176,151,100.13	Cash Box

WHEN ORDERING PARTS INDICATE MODEL # AND SERIAL # OF VENDER
ALL PRICES ARE SUBJECT TO CHANGE WITHOUT NOTICE.

INNER DOOR

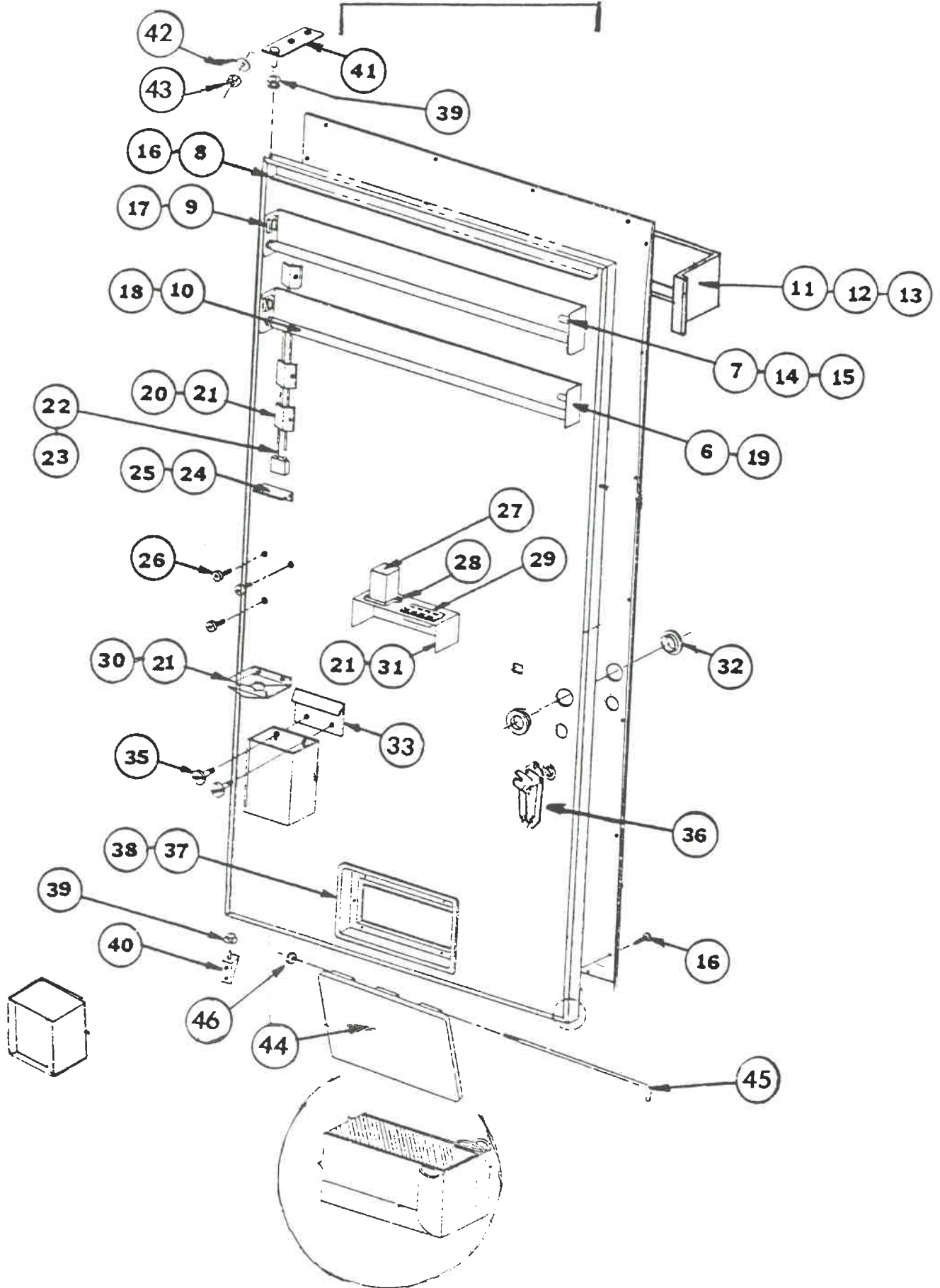

ITEM NO.	PART NUMBER	PART NAME AND DESCRIPTION
	DCB156/93-6 - DCB228/132-6 - DCB264/156-6 - DCB318/183-6	
1	C258,050,200.03	Selector Panel Ass'y.
2	C251,050,100.03	Selector Panel, W/A
3	D258,050,010.03	Cover, Selector Panel
4	C176,073,300.03	Wiring Harness, Selector Panel
	DCB304/176-8 - DCB352/208-8 - DCB424/244-8	
1	C242,050,200.03	Selector Panel Ass'y.
2	C241,050,300.03	Selector Panel W/A
3	D242,050,010.03	Cover, Selector Panel
4	C241,050,200.03	Wiring Harness, Selector Panel
	DCB156/93-6 - DCB228/132-6 - DCB264/156-6 - DCB318/183-6 - DCB304/176-8 DCB352/208-8 - DCB424/244-8	
5	804,100,400.01	Select Switch
6	A901,700,430.01	Spring, Select Switch
7	905,800,400.01	Insulator - Switch
8	A208,050,150.73	Support - Switch
9	A143,051,220.73	Retainer - Coin Insert
10	900,300,160.01	Screw, S/M #6 x 1/2
11	801,804,310.01	Coin Chute, Gray
12	801,804,320.01	Cover, Coin Chute, Gray
13	A208,050,120.33	Retainer - Coin Plunger
14	A901,700,630.01	Spring, Coin Plunger
15	B801,303,510.11	Coin Return Plunger
16	D801,200,920.21	Coin Insert - Only
17	A904,700,180.21	Correct Change Lamp
18	903,809,320.01	Instruction Label (Specify price)
19	901,100,500.01	Blind Rivet
20	A801,803,880.11	Select Button Ass'y. - PEPSI
21	A801,803,890.01	Select Button Ass'y. - PLAIN
22	804,700,210.01	Sold Out Lamp
23	903,807,690.01	Flavor Strip (Specify Flavor)
24	A903,805,040.01	Strip 12 oz. Cans
25	903,806,020.01	Identification Label, 1 thru 6
26	801,804,270.01	Select Button Ass'y. - DIET PEPSI
27	801,804,280.01	Select Button Ass'y. - MOUNTAIN DEW

WHEN ORDERING PARTS, INDICATE MODEL # AND SERIAL # OF VENDER.
ALL PRICES ARE SUBJECT TO CHANGE WITHOUT NOTICE.

WIRING HARNESS — DOOR & CABINET

Parts

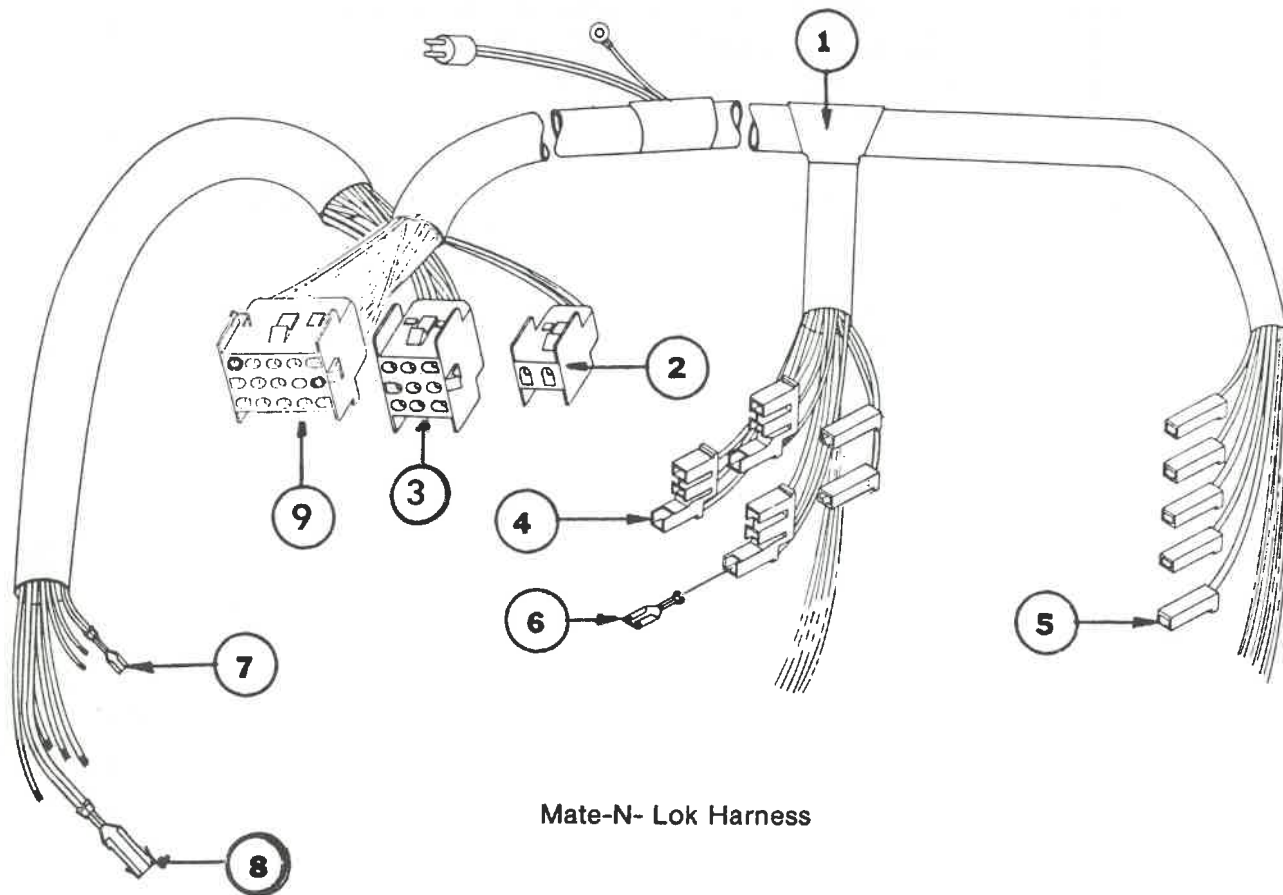

Mate-N- Lok Harness

Parts List

WIRING HARNESS - DOOR AND CABINET

ITEM NO.	PART NUMBER	PART NAME AND DESCRIPTION
1	DCB156/93-6 - DCB228/132-6 - DCB264/156-6 - DCB318/183-6 F251,070,100.03	Wiring Harness, Door & Cabinet
1	DCB304/176-8 - DCB352/208-8 - DCB424/244-8 F241,070,100.03	Wiring Harness, Door & Cabinet
	DCB156/93-6 - DCB228/132-6 - DCB264/156-6 - DCB318/183-6 - DCB304/176-8 DCB352/208-8 - DCB424/244-8	
2	904,600,700.01	Mate-N-Lok Cap, 2-way
3	904,600,660.01	Mate-N-Lok Cap, 9-way
4	904,600,560.01	Receptacle Housing (187)
5	904,600,040.01	Receptacle Housing (250)
6	904,600,520.01	Faston Receptacle (187)
7	904,600,530.01	Faston Receptacle (187) 2 wire
8	904,600,380.01	Faston Receptacle (250) 2 wire
9	904,600,820.01	Mate-N-Lok Cap, 15-way

WHEN ORDERING PARTS INDICATE MODEL # AND SERIAL # OF VENDER.
ALL PRICES SUBJECT TO CHANGE WITHOUT NOTICE.

HINGES ASSY. LIFTER & ROLLER

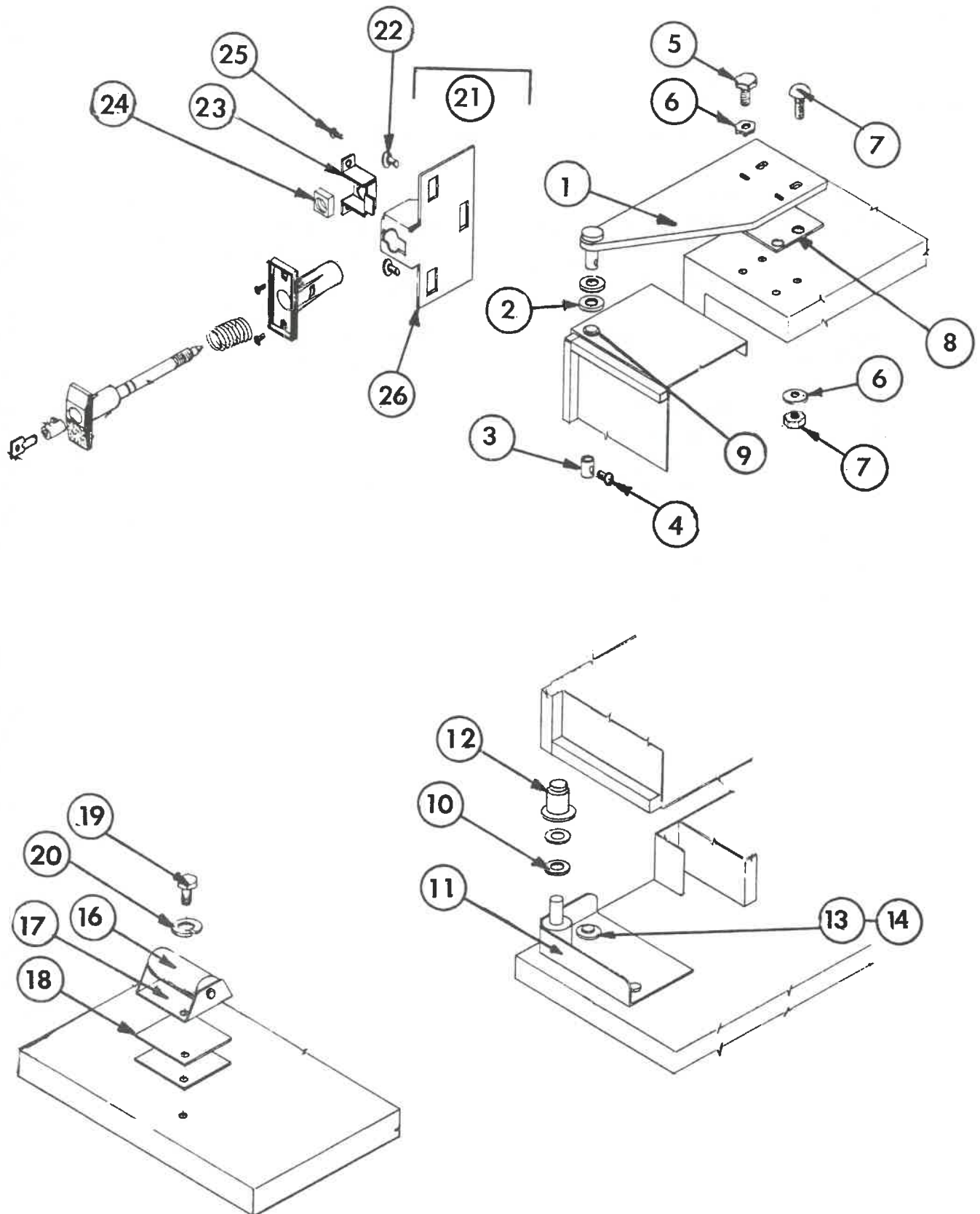

Parts List

HINGES ASSY. LIFTER & ROLLER

ITEM NO.	PART NUMBER	PART NAME AND DESCRIPTION
DCB156/93-6 - DCB228/132-6 - DCB264/156-6 - DCB318/183-6 - DCB304/176-7 DCB352/208-8 - DCB424/244-8		
1	B801,501,710.31	Top Hinge
2	900,700,600.01	Flat Washer
3	A800,502,030.01	Collar - Hinge Pin
4	A900,201,260.01	Lock Screw
5	900,900,470.02	Cap Screw
6	903,000,070.02	Lockwasher, 1/4 - 20
7	900,201,170.01	Carriage Bolt and Nut
8	A169,000,150.13	Hinge Spacer
9	801,803,170.01	Bearing Nyliner
10	900,700,530.01	Washer
11	B169,000,100.93	Bottom Hinge, W/A
12	A901,800,330.51	Flanged Bushing
13	900,700,710.01	Lockwasher
14	900,900,470.02	Screw Machine, 1/4 x 20 x 3/4
16	A801,801,330.51	Roller
17	A142,161,700.63	Assembly Lifter and Roller
18	A142,160,580.43	Spacer - Roller Bracket
19	900,200,290.01	Screw Machine, 10-24 x 3/4
20	903,000,170.02	Lockwasher
21	B169,000,080.83	Latch Strike Assembly
22	900,900,470.02	Screw Machine, 1/4 - 20 x 3/4"
23	B801,303,320.61	Nut - Housing
24	A900,800,570.11	Nut
25	900,301,560.01	Screw, Sems
26	B176,150,160.33	Nut Retainer Housing

WHEN ORDERING PARTS, INDICATE MODEL # AND SERIAL # OF VENDER.
ALL PRICES ARE SUBJECT TO CHANGE WITHOUT NOTICE.

PULL-OUT HANDLE

Parts

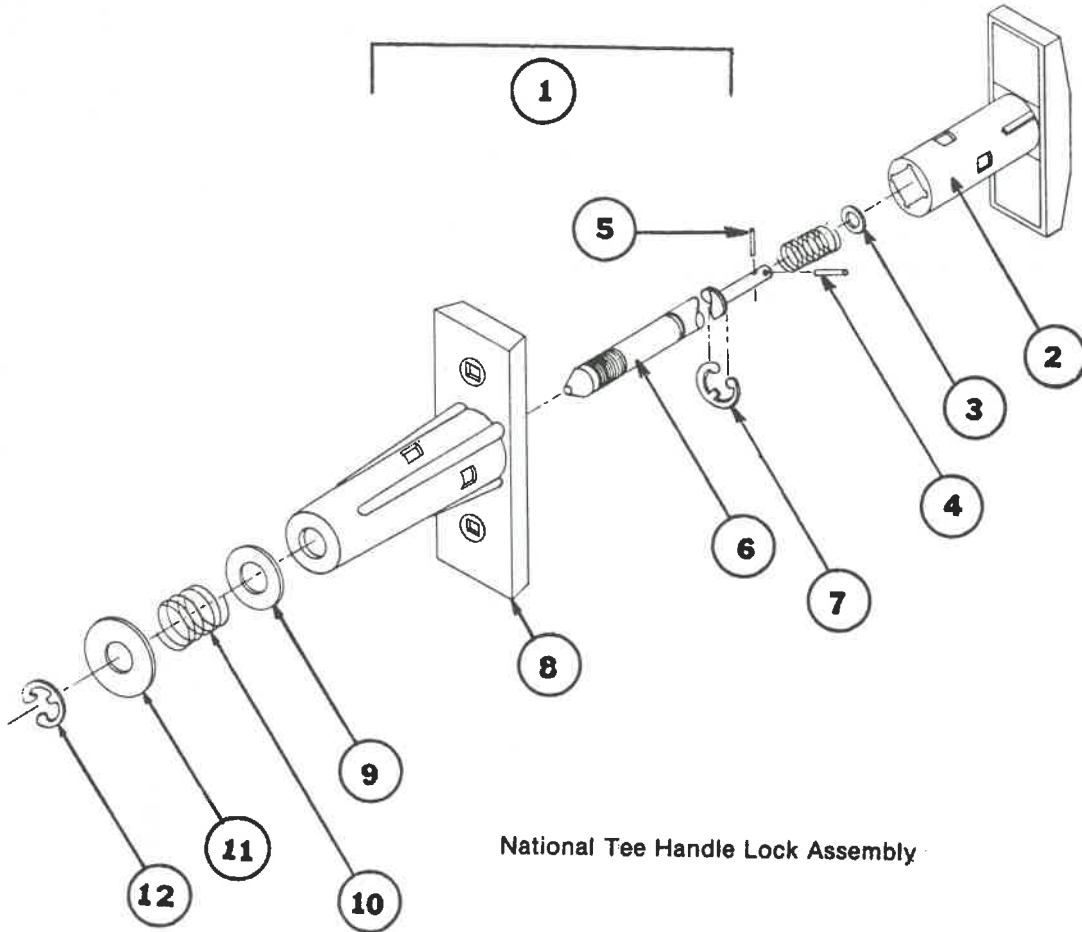

National Tee Handle Lock Assembly

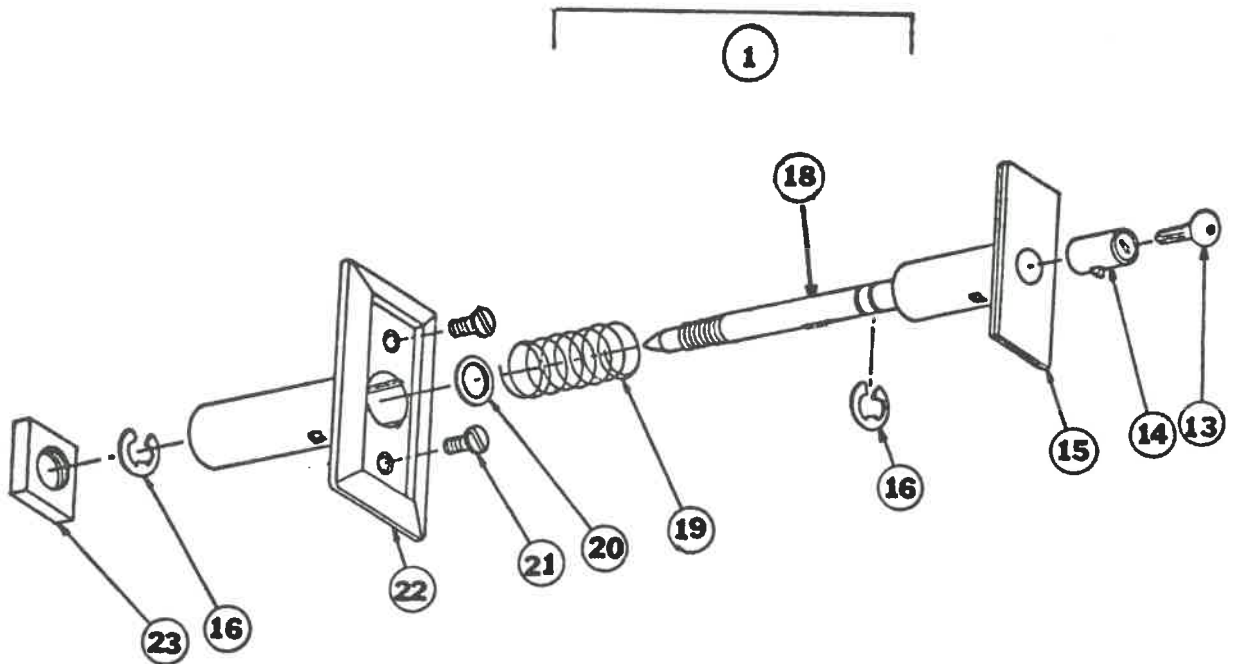

Chicago Tee Handle Lock Assembly

Parts List

PULL-OUT HANDLE

ITEM NO.	PART NUMBER	PART NAME AND DESCRIPTION
	DCB 156/93-6 - DCB228/132-6 - DCB264/156-6 - DCB318/183-6 DCB304/176-8 - DCB352/208-8 - DCB424/244-8	
1	801,501,860.31	Pull Out Handle (complete)
2	NI-0472-103-6	Handle
3	NI-0472-255	Spring Support Washer
4	NI-0472-256	Pin
5	NI-0472-254	Pin
6	NI-0472-253-1	Spindle
7	NI-0472-132-1	Retaining Ring
8	NI-0472-102-6	Handle Pocket
9	NI-0472-133-1	Inside Washer
10	NI-0472-255-1	Spring
11	NI-0472-129-1	Washer
12	NI-0472-132-1	Retaining Ring
13		Key, Specify Key Number
14	801,501,470.01	Locks w/2 Keys
15	4265-2	Handle
16	31-5	C-Clip
18	4255-6-43W	Bolt Threaded, short
19	901,700,640.01	Spring
20	900,700,760.01	Washer
21	900,901,510.02	Screw, machine, 10-32 x 5/8
22	4265-1	Body
23	A900,800,570.11	Nut, Square, 1/2 x 13

WHEN ORDERING PARTS, INDICATE MODEL # AND SERIAL # OF VENDER
ALL PRICES ARE SUBJECT TO CHANGE WITHOUT NOTICE.

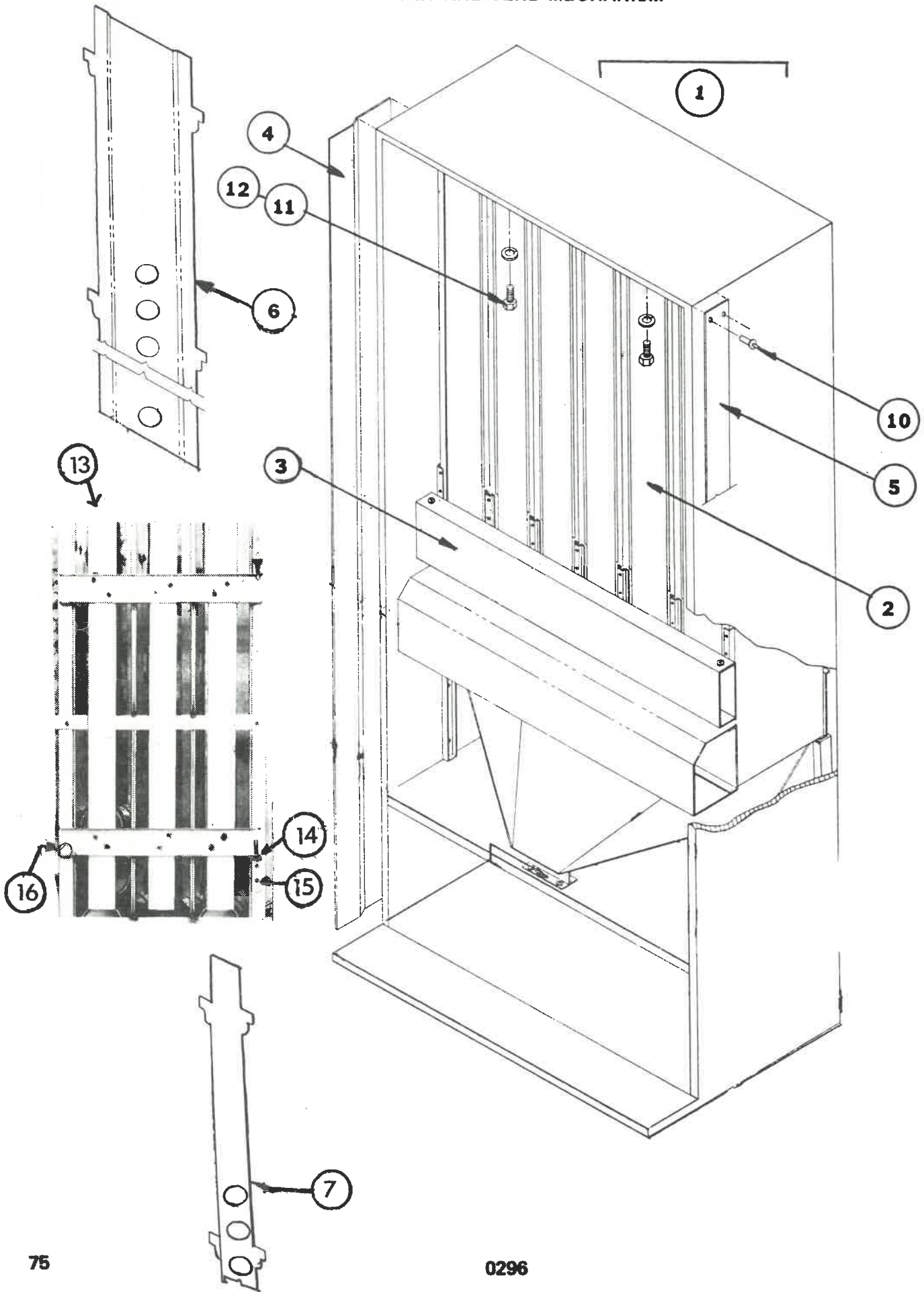

CABINET AND VEND MECHANISM

ITEM NO.	PART NUMBER	PART NAME AND DESCRIPTION
		DCB156/93-6
1	D154,060,001.73	Cabinet Ass'y., Less Stack
2	D214,070,000.13D	Vend Mechanism Complete
3	F237,071,000.03D	Stack w/Ass'y. w/Gate installed
4	C168,000,030.83	Protective Plate L.S. Cabinet
5	C168,000,040.83	Protective Plate R.S. Cabinet
6	C173,070,130.23	Bottle Guide Standard Column
7	C245,070,100.01	Bottle Guide Narrow Column
10	901,100,440.01	Drive Rivet 1/4 Protective Plate Cabinet
11	900,900,470.01	Cap Screw
12	903,000,070.01	Washer
13	C245,070,200.03	W/A Gate
14	A231,070,300.03	W/A Gate Hinge
15	901,100,390.01	Pop Rivet
16	A231,070,260.03	Gate Latch
		DCB228/132-7
1	D155,060,001.73	Cabinet Ass'y., Less Stack
2	D214,070,000.13C	Vend Mechanism Complete
3	F237,071,000.03C	Stack w/Ass'y. w/Gate Installed
4	C166,000,040.93	Protective Plate L.S. Cabinet
5	B166,000,040.83	Protective Plate R.S. Cabinet
6	C172,070,130.33	Bottle Guide Standard Column
7	C240,070,100.23	Bottle Guide Narrow Column
10	901,100,440.01	Drive Rivet 1/4 Protective Plate Cabinet
11	900,900,470.01	Cap Screw
12	903,000,070.01	Washer
13	C237,070,500.03	W/A Gate
14	A231,070,300.03	W/A Gate Hinge
15	901,100,390.01	Pop Rivet
16	A231,070,260.03	Gate Latch
		DCB264/156-6
1	D215,060,000.23	Cabinet Ass'y., Less Stack
2	D214,070,000.13B	Vend Mechanism Complete
3	F237,071,000.03B	Stack w/Ass'y. w/Gate Installed
4	C165,000,030.73	Protective Plate L.S. Cabinet
5	B165,000,040.73	Protective Plate R.S. Cabinet
6	C165,070,331.03	Bottle Guide Standard Column
7	C239,070,100.23	Bottle Guide Narrow Column
10	901,100,440.01	Drive Rivet 1/4 Protective Plate Cabinet
11	900,900,470.01	Cap Screw
12	903,000,070.02	Washer
13	C237,070,500.03	W/A Gate
14	A231,070,300.03	W/A Gate Hinge
15	901,100,390.01	Pop Rivet
16	A231,070,260.03	Gate Latch

WHEN ORDERING PARTS, INDICATE MODEL # AND SERIAL # OF VENDER.
ALL PRICES ARE SUBJECT TO CHANGE WITHOUT NOTICE.

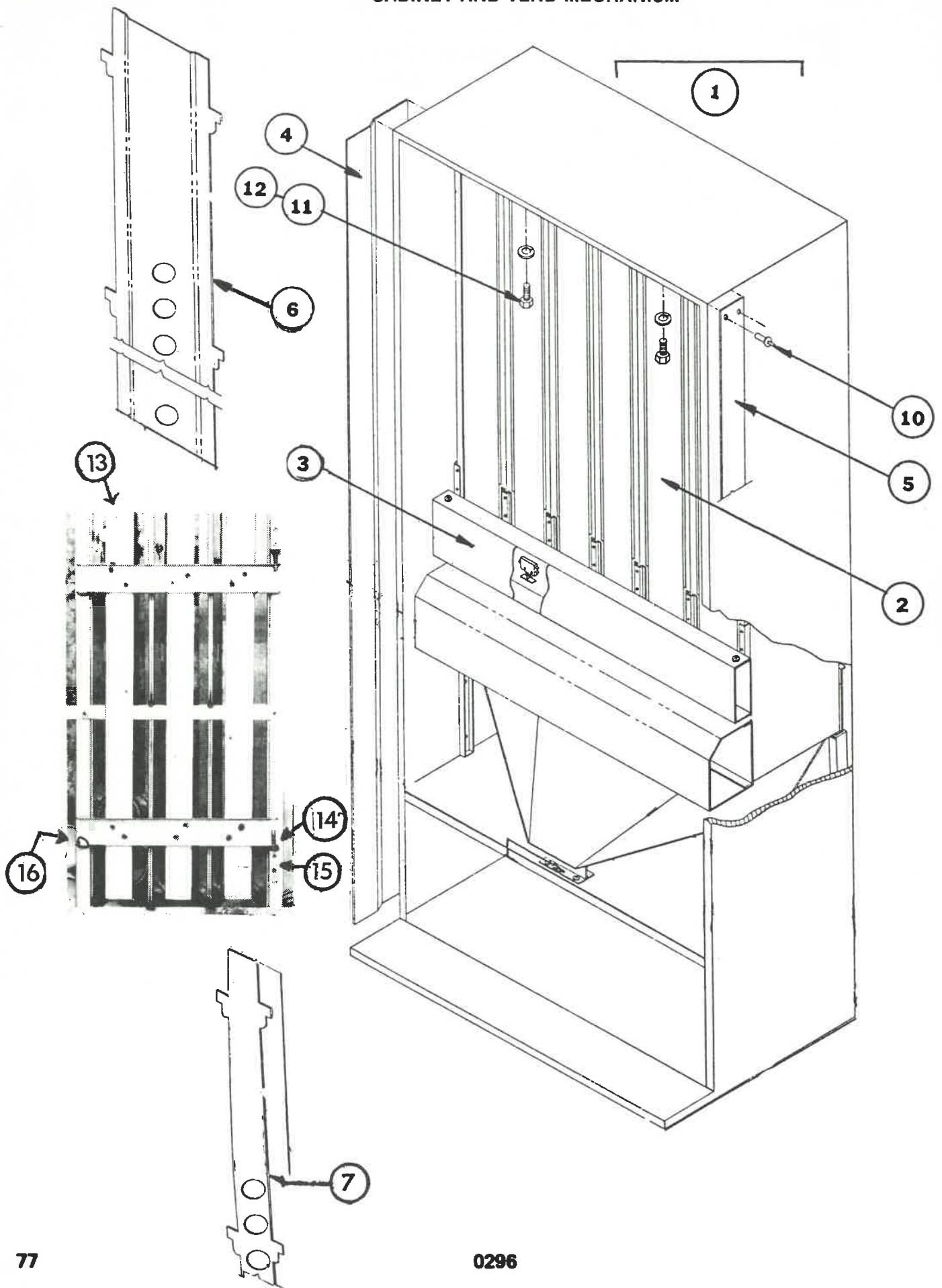

CABINET AND VEND MECHANISM

ITEM NO.	PART NUMBER	PART NAME AND DESCRIPTION
		DCB318/183-6
1	D156,060,001.53	Cabinet Ass'y., less Stack
2	D214,070,000.13A	Vend Mechanism Complete
3	D237,071,000.03A	Stack w/Ass'y. w/Gate Installed
4	C164,000,030.93	Protective Plate L.S. Cabinet
5	B164,000,040.93	Protective Plate R.S. Cabinet
6	C164,070,331.23	Bottle Guide Standard Column
7	C231,070,500.23	Bottle Guide Narrow Column
10	901,100,440.01	Drive Rivet 1/4 Protective Plate Cabinet
11	900,900,470.01	Cap Screw
12	903,000,070.02	Washer
13	C237,070,500.03	W/A Gate
14	A231,070,300.03	W/A Gate Hinge
15	901,100,390.01	Pop Rivet
16	A231,070,260.03	Gate Latch
		DCB304/176-8
1	D166,060,001.13	Cabinet Ass'y., less Stack
2	C211,070,000.03C	Vend Mechanism Complete
3	F231,071,000.03C	Stack w/Ass'y. w/Gate Installed
4	C166,000,030.93	Protective Plate L.S. Cabinet
5	B166,000,040.83	Protective Plate R.S. Cabinet
6	C172,070,130.33	Bottle Guide Standard Column
7	C240,070,100.23	Bottle Guide Narrow Column
10	901,100,440.01	Drive Rivet 1/4 Protective Plate Cabinet
11	900,900,470.01	Cap Screw
12	903,000,070.01	Washer
13	A231,070,100.03	W/A Gate
14	A231,070,300.03	W/A Gate Hinge
15	901,100,390.01	Pop Rivet
16	A231,070,260.03	Gate Latch
		DCB352/208-8
1	D165,060,001.23	Cabinet Ass'y., Less Stack
2	C211,070,000.03B	Vend Mechanism Complete
3	F231,071,000.03B	Stack w/Ass'y. w/Gate installed
4	C165,000,030.73	Protective Plate L.S. Cabinet
5	B165,000,040.73	Protective Plate R.S. Cabinet
6	C165,070,331.03	Bottle Guide Standard Column
7	C239,070,100.23	Bottle Guide Narrow Column
10	901,100,440.01	Drive Rivet 1/4 Protective Cabinet
11	900,900,470.01	Cap Screw
12	903,000,070.02	Washer
13	A231,070,100.03	W/A Gate
14	A231,070,300.03	W/A Gate Hinge
15	901,100,390.01	Pop Rivet
16	A231,070,260.03	Gate Latch

WHEN ORDERING PARTS, INDICATE MODEL # AND SERIAL # OF VENDER.
ALL PRICES ARE SUBJECT TO CHANGE WITHOUT NOTICE.

CABINET AND VEND MECHANISM

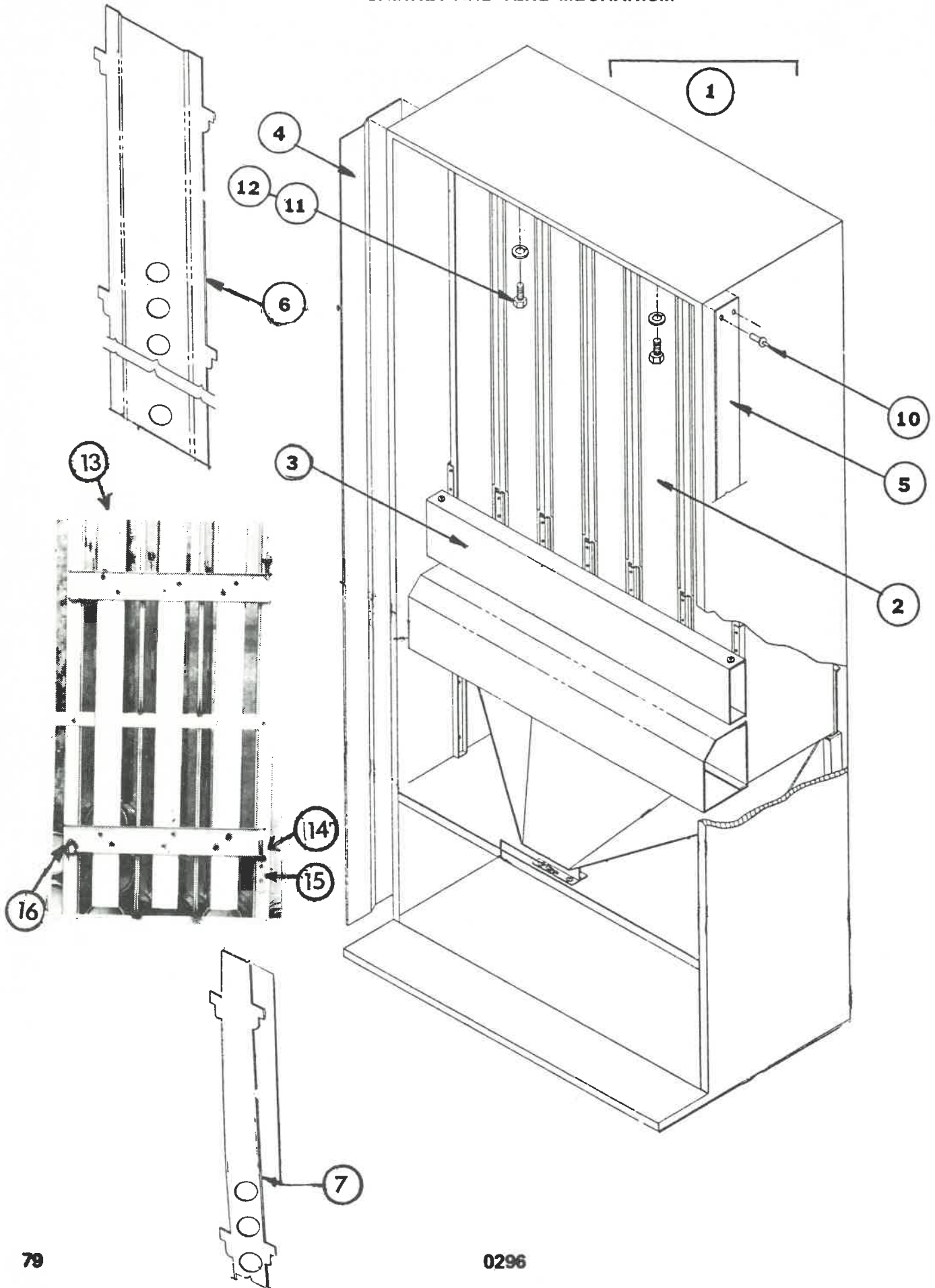

Parts List

CABINET AND VEND MECHANISM

ITEM NO.	PART NUMBER	PART NAME AND DESCRIPTION
		DCB424/244-8
1	D164,060,001.23	Cabinet Ass'y., Less Stack
2	C211,070,000.03A	Vend Mechanism Complete
3	F231,070,000.03A	Stack w/Ass'y. w/Gate Installed
4	C164,000,030.93	Protective Plate L.S. Cabinet
5	B164,000,040.93	Protective Plate R.S. Cabinet
6	C164,070,331/23	Bottle Guide Standard Column
7	C231,070,500.23	Bottle Guide Narrow Column
10	901,100,440.01	Drive Rivet 1/4 Protective Plate Cabinet
11	900,900,470.01	Cap Screw
12	903,000,070.02	Washer
13	A231,070,100.03	W/A Gate
14	A231,070,300.03	W/A Gate Hinge
15	901,100.390.01	Pop Rivet
16	A231,070,260.03	Gate Latch

WHEN ORDERING PARTS, INDICATE MODEL # AND SERIAL # OF VENDER.
ALL PRICES ARE SUBJECT TO CHANGE WITHOUT NOTICE.

CABINET AND VEND MECHANISM

ITEM NO.	PART NUMBER	PART NAME AND DESCRIPTION
DCB156/93-6 - DCB228/132-6 - DCB264/156-6 - DCB318/183-6		
1	B237,070,250.03	Cover, Vend Motor
2	B237,070,080.03	Cover, Sold Out Switch, S/A
3	C208,070,100.43	Can & Bottle Chute Ass'y. (Complete)
4	D208,070,020.43	Liner Only, Chute
DCB352/208-8 - DCB304/176-8 - DCB424/244-8		
1	C176,070,250.03	Cover, Vend Motor
2	B231,070,220.03	Cover, Sold Out Switch, S/A
3	C211,070,100.13	Can & Bottle Chute Ass'y. (Complete)
4	B211,070,020.23	Liner Only, Chute
DCB156/93-6 - DCB228/132-6 - DCB264/156-6 - DCB318/183-6 - DCB304/176-8 DCB352/208-8 - DCB424/244-8		
5	B147,074,400.73	Bracket Chute
6	900,900,960.02	Hex Nut - 10-32 (Chute)
7	900,301,560.01	Screw Sems - (Cover, Vend Motor)
8	801,200,940.11	Oscillator Standard Stack
9	801,200,980.21	Vend Rotor (Narrow Column)
10	801,803,170.01	Nyliner (rear stack)
11	801,804,230.01	Nyliner (Oscillator front)
12	C231,070,400.03	Vend Motor (Narrow Column)
13	179,070,600.33	Vend Motor (Red Cam Standard Column)
14	804,100,500.01	Cluster Switch, Vend Motor
15	900,301,610.01	Screw, Vend Motor Switch
16	905,800,330.01	Insulator - Vend Motor Switch
17	C801,804,090.21	Vend Motor Cam - (RED) Standard Stack
18	C801,804,000.41	Adjustable Cam - (WHITE) Standard Stack
19	C801,804,290.01	Adjustable Cam - (RED) Narrow Column
20	C801,804,090.01	Cam, Vend Motor (Narrow Column)
21	804,100,490.01	Switch, Sold Out Cluster
22	900,301,670.01	Screw, Sold Out Switch #4 x 1 1/4"
23	C231,070,170.43	Paddle, Sold Out Switch
24	901,700,630.01	Spring, Sold Out Paddle
25	801,804,350.01	Insulator, Switch
26	C801,804,390.21	Shims, 12oz. Can (Plastic)
27	B143,000,301.03	Fan Motor S/A - Evap.
28	901,303,270.01	Fan Balde -- Evap.
29	900,100,970.02-2	Silencer
30	900,100,970.02-1	Speed Nut
31	B164,040,080.63	Bracket, Fan Motor
32	900,300,320.01	Screw, Self Tapping (10-24)
33	B169,000,200.63	Ass'y. Pan & Soaker
34	C801,804,240.11	Condensate Pan (Only Black)
35	901,900,020.01	Soakers
36	901,900,020.01	Rod, for Soaker 14"
37	900,301,650.01	Screw, Self Drilling

WHEN ORDERING PARTS, INDICATE MODEL # AND SERIAL # OF VENDER.
ALL PRICES ARE SUBJECT TO CHANGE WITHOUT NOTICE.

REFRIGERATION SYSTEM

Parts

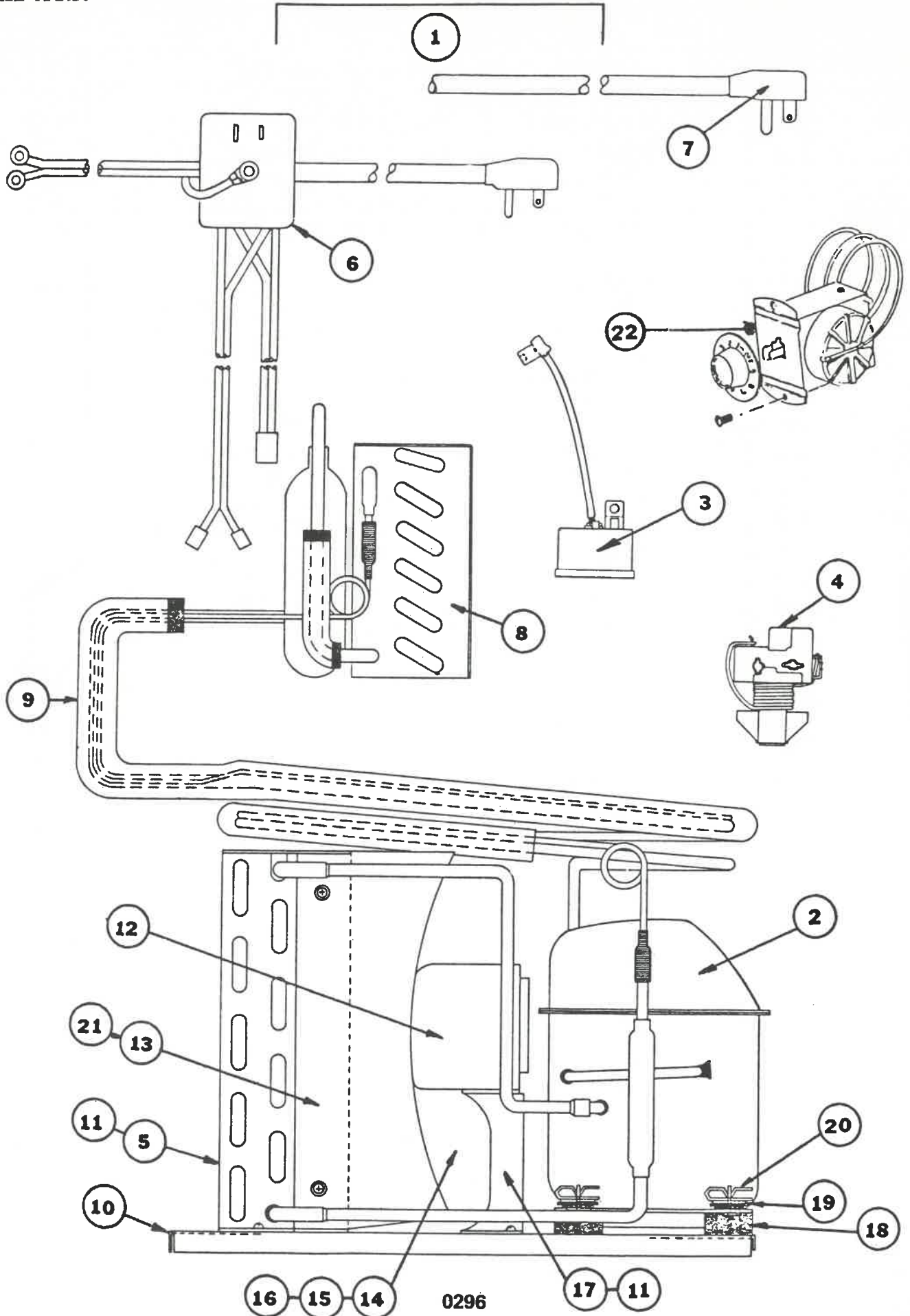

REFRIGERATION SYSTEM

ITEM NO.	PART NUMBER	PART NAME AND DESCRIPTION
		DCB156/93-6 - DCB228/132-6
1	D142,040,002.43	Refrigeration System Complete, Model 400
2	802,500,110.01	Compressor, Model AE3430A Tecumseh
2	802,500,110.01	Compressor, 1/4 H.P. Americold
3	83458	Overload for AE3430A compressor Tecumseh
*	(SPMRP-26 ALL-34)	Overload for AE3430A compressor Tecumseh
3	1456-3163	Overload for 1/4 H.P. Americold
*	MST22ALK-319	Overload for 1/4 H.P. Americold
4A	82684	Relay for AE3430A Compressor Tecumseh
*	(SP9660-040-176)	Relay for AE3430A Compressor Tecumseh
4B	82483	Relay for AE3430A Compressor Tecumseh
*	(GE3ARR12-PB162)	Relay for AE3430A Compressor Tecumseh
4	1456-3164	Relay for 1/4 H.P. Americold
*	3CR-203-180	Relay for 1/4 H.P. Americold
5	C808,600,540.02	Condenser
		DCB264/156-6 - DCB318/183-6 - DCB304/176-8 - DCB252/208-8 DCB424/244-8
1	D143,040,402.13	Refrigeration System Complete, Model 300
2	802,500,170.01	Compressor, Model AE3440A Tecumseh
3	TEC8300MRTA78	Overload for AE3440A compressor Tecumseh
*	(SPMRT-22AIN-34)	Overload for AE3440A Compressor Tecumseh
4A	TEC8209660A09	Relay for AE3440A Compressor Tecumseh
*	(SP9660-040-182)	Relay for AE3440A Compressor Tecumseh
4B	820RR12A10	Relay for AE3440A Compressor Tecumseh
*	(GE3ARR12-PB220)	Relay for AE3440A Compressor Tecumseh
5	D808,700,090.02	Condenser
		DCB156/93-6 - DCB228/132-6 - DCB264/156-6 - DCB318/183-6 - DCB304/176-8 DCB252/208-8 - DCB424/244-8
6	C804,900,601.51	Main Wiring Harness
7	A904,900,610.81	Compressor Lead w/plug
8	B802,600,370.51	Evaporator
9	903,300,530.01	Insulator Tube
10	C164,040,120.43	Base Plate - Condensing Unit
11	900,301,560.01	Screw Sems
12	802,302,120.02	Fan Motor
13	902,100,160.02	Shroud
14	900,103,370.02	Fan Blade
15	900,100,970.02-2	Silencer
16	900,100,970.02-1	Speed Nut
17	900,102,970.02	Fan Bracket
18	902,000,570.01	Grommet, Compressor Mounting
19	A901,803,910.11	Plug, Compressor Grommet
20	A900,901,880.01	Retainer Clip, Compressor Mounting
21	900,300,160.01	Screw, S/M #6 x 3/8
22	802,800,090.01	Temperature Control

*Relative to Relays & Overloads, the numbers that appear in parenthesis () are always stamped on the Relay & Overload. Either # can be used for ordering purposes.

WHEN ORDERING PARTS, INDICATE MODEL # AND SERIAL # OF VENDER.

ALL PRICES ARE SUBJECT TO CHANGE WITHOUT NOTICE.

